

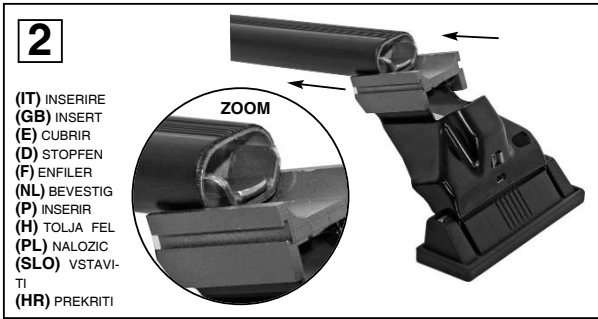

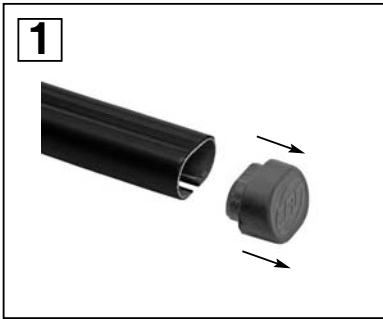

**(IT) Attenzione:** Istruzioni di montaggio per barre in ferro.  
**(GB) Attention:** Mounting instructions for steel bar carriers.  
**(E) Atención:** Instrucciones de montaje para barras portatodo en hierro.  
**(D) Achtung:** Montageanweisungen für Stahl-Lastenträger.  
**(F) Attention:** Notices de montage pour barres de portage en métal.  
**(NL) Attentie:** Handleiding voor dakdragers gemaakt van ijzer.  
**(P) Atenção:** Intruções de montagem para barras de tejadilho em ferro.  
**(H) Szerelési utasítás:** acél tartórudakhoz.  
**(PL) Uwaga:** Instrukcja montażu bagażników wykonanych ze stali.  
**(SLO) Pozor:** Navodila za montažo o nosilcev prtljač nika-č eleznih.  
**(HR) Uputstvo za montažu:** o nosilcev prtljač nika-č eleznih.





**3**

		
<b>(IT) MODELLI AUTO</b> <b>(GB) CARS</b> <b>(E) COCHES</b> <b>(D) WAGEN</b> <b>(F) VOITURES</b>	<b>(NL) AUTO</b> <b>(P) MODELO AUTO</b> <b>(H) AUTO TIPUS</b> <b>(SLO) MODELI AVTOMOBILOV</b> <b>(HR) MODELI AVTA</b>	<b>(IT) ANTERIORE</b> <b>(GB) FRONT</b> <b>(E) DELANTERO</b> <b>(D) VORDERE</b> <b>(F) AVANT</b>
	<b>(NL) VOOR-STE G.</b> <b>(P) A FRENTE</b> <b>(H) ELSŐ RÜD</b> <b>(PL) PRZOD</b> <b>(SLO) SPREDAJ</b> <b>(HR) PREDNJI</b>	<b>(NL) ACHTERSTE G.</b> <b>(P) ATRAS</b> <b>(H) HÁTSÓ RÜD</b> <b>(PL) TYŁ</b> <b>(SLO) ZADAJ</b> <b>(HR) STRACNJI</b>
<b>VOLVO 850</b>		
<b>VOLVO V70</b>		
<b>VOLVO S70</b>	<b>56 mm.</b>	<b>75 mm.</b>

**(IT) MISURE PRECISE**  
**(GB) EXACT DIMENSIONS**  
**(E) MEDIDAS CORRECTAS**  
**(D) GENAU MASSE**  
**(F) MESURES EXACTES**  
**(NL) EXACTE AFMETINGEN**  
**(P) MEDIDAS PRECISAS**  
**(H) PONTOS MÉRET**  
**(PL) DOKŁADNE WYMIARY**  
**(SLO) TO-NE MERE**  
**(HR) PRECIZNE MJERE**

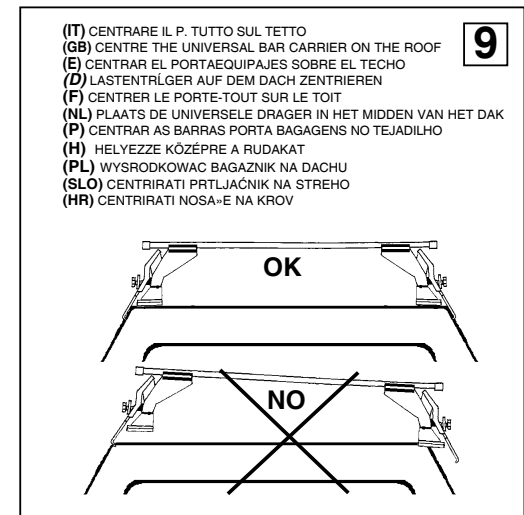
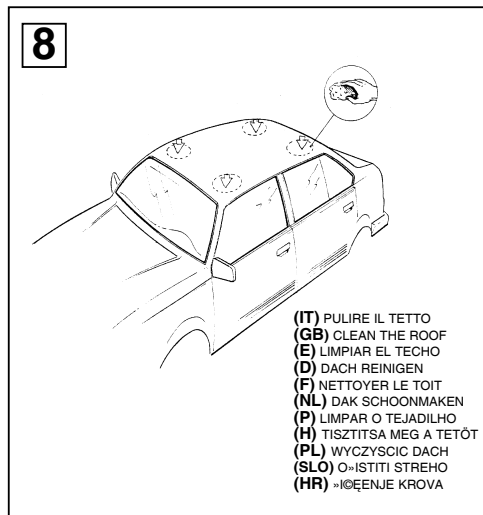
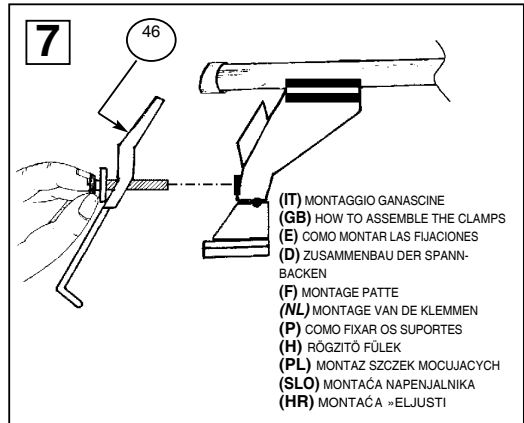
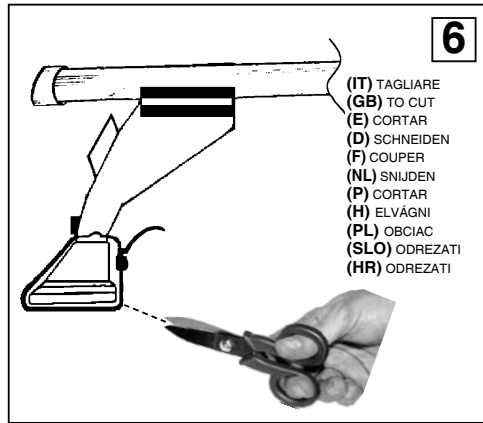
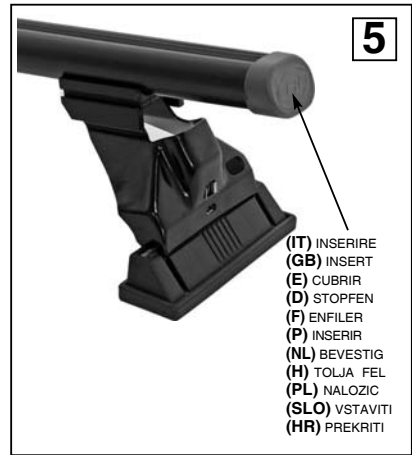
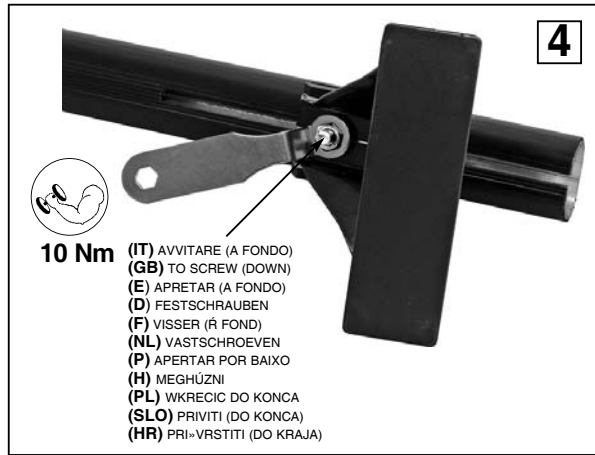

(IT) MODELLI CON PREDISPOSIZIONE DELLA CASA AUTO  
 (GB) CARS WITH PRE-EXISTING FIXING POINT FROM MANUFACTURER  
 (E) MODELOS CON PREDISPOSICION DEL FABRICANTE  
 (D) AUTOS MIT VOM HERSTELLER VORGESEHENE BEFESTIGUNGSPUNKTE  
 (F) VOITURES AVEC POINTS DE RÉPÔRE PREVUS PAR LE CONSTRUCTEUR  
 (NL) AUTO'S MET DOOR DE FABRIKANT VOORZIENE MONTAGEPUNTEN  
 (P) VIATURAS COM PONTOS DE FIXAÇÃO DO CONSTRUTOR PRÉ-EXISTENTES  
 (H) FELHELYEZÉS GYÁRTÓ ÁLTAL KIJELÖLT PONTRA  
 (PL) SAMOCHODY Z PRZEWDZIANYMI PUNKTAMI UMOCOWANIA  
 (SLO) MODELI Z PREDVIDENIM LE" I "»EM S STRANI PROIZVAJALCA  
 (HR) TVORNI»KI PRIPREMLJENI MODELI

"À TROUVER SUR LE BATTANT DE LA PORTE OU  
 DANS LE MANUAL TECHNIQUE DE LA VOITURE "

10

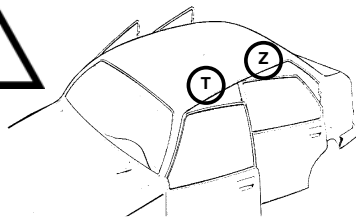

(IT) MODELLI AUTO	(IT) ANTERIORE	(IT) POSTERIORE
(GB) CARS	(GB) FRONT	(GB) REAR
(E) COCHES	(E) DELANTERO	(E) TRASERO
(D) WAGEN	(D) VORDERE	(D) HINTERE
(F) VOITURES	(F) AVANT	(F) ARRIERE
(NL) AUTO	(NL) VOORSTE G.	(NL) ACHTERSTE G.
(P) MODELO AUTO	(P) À FRENTE	(P) ATRÁS
(H) AUTÓ TIPUS	(H) ELSŐ RÚD	(H) HÁTSÓ RÚD
(SLO) MODELI AVTOMOBILOV	(PL) PRZOD	(PL) TYŁ
(HR) MODELI AUTA	(SLO) SPREDAJ	(SLO) ZADAJ
	(HR) PREDNJI	(HR) STRA`NJI

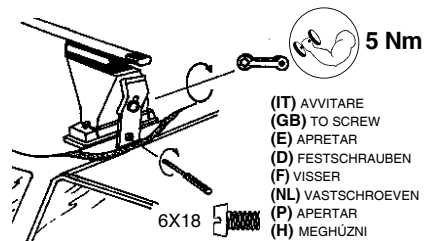

5 Nm

(IT) AVVITARE  
 (GB) TO SCREW  
 (E) APRETAR  
 (D) FESTSCHRAUBEN  
 (F) VISSER  
 (NL) VASTSCHROEVEN  
 (P) APERTAR  
 (H) MEGHÚZNI  
 (PL) WKRECIĆ  
 (SLO) PRIVITI  
 (HR) PRI»VRSTITI

VW POLO 5P (02->)  
 VW TOURAN NO RAILS

T	Z
T	Z