



Attenzione: Istruzioni di montaggio per barre in ferro.
Attention: Notices de montage pour barres de portage en fer.
Attention: Mounting instructions for bar-carriers made of iron.
Atencion: Instrucciones de montaje para barras portatodo en hierro.
Achtung: Montageanweisungen fuer lastentraeger aus eisen.
Attentie: Handleiding voor dakdragers gemaakt van ijzer.
Uwaga: Instrukcja montazu bagaznikow wykonanych ze stali.
Pozor: Navodila za montažo nosilcev prtljažnika - železnih.
 Szerelési utasítás acél tartórudakhoz.



1



2

INSERIRE
 INSERT
 CUBRIR
 STOPFEN
 ENFILER
 BEVESTIG
 TOLJA FEL
 NALOZIC
 VSTAVITI.

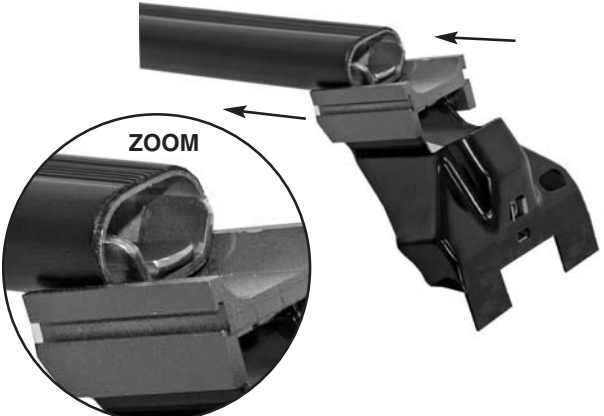

ZOOM

3



INSERIRE
 INSERT
 CUBRIR
 STOPFEN
 ENFILER
 BEVESTIG
 TOLJA FEL
 NALOZIC
 VSTAVITI.

4

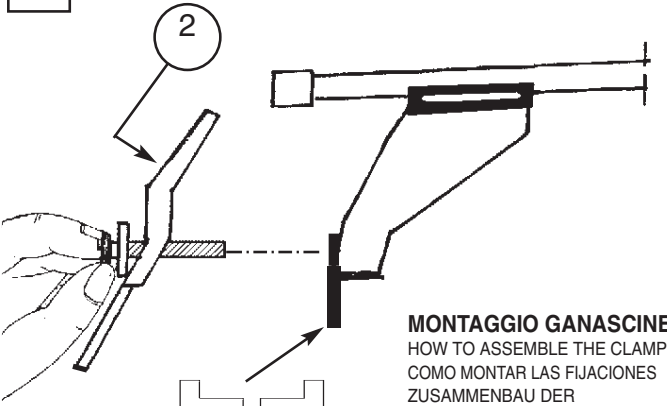

MONTAGGIO GANASCINE
 HOW TO ASSEMBLE THE CLAMPS
 COMO MONTAR LAS FIJACIONES
 ZUSAMMENBAU DER
 SPANNBACKEN
 MONTAGE CROCHET
 MONTAGE VAN DE KLEMMEN
 RÖGZITŐ FÜLEK
 MONTAZ SZCZEK MOCUJACYCH
 MONTAŽA NAPENJALNIKA

GUARNIZIONE
 GASKET
 MOLDURA
 HERAUSZEHEN
 GUARNITURE
 LOSMAKEN

5

CENTRARE IL P. TUTTO SUL TETTO
 CENTRE THE UNIVERSAL BAR CARRIER ON THE ROOF
 CENTRAR EL PORTAEQUIPAJES SOBRE EL TECHO
 LASTENTRÄGER AUF DEM DACH ZENTRIEREN
 CENTRER LE TOIT AVEC LE PORTE-TOUT
 PLAATS DE UNIVERSELE DRAGERIN HET MIDDEN VAN HET DAK
 HELYEZZE KÖZÉPRE A RUDAKAT
 WYSRODKOWAC BAGAZNIK NA DACHU
 CENTRIRATI PRTLJAŽNIK NA STREHO

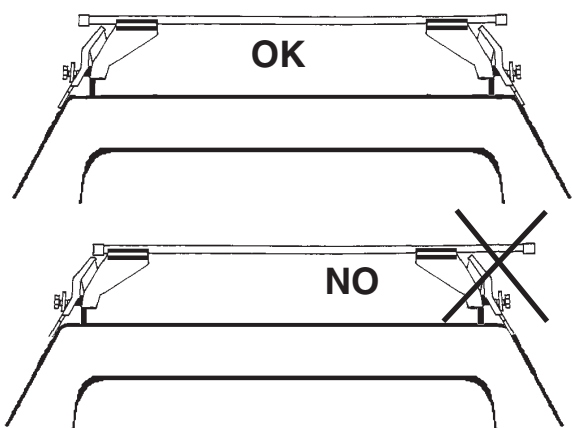

OK

NO

6

MODELLI CON PREDISPOSIZIONE DELLA CASA AUTO:
 CARS WITH PRE-EXISTING FIXING POINT FROM MANUFACTURER
 MODELOS CON PREDISPOSICION DEL FABRICANTE
 AUTOS MIT VOM HERSTELLER VORGESEHENE BEFESTIGUNGSPUNKTE
 VOITURES AVEC POINTS DE FIXAGE PREVUS PAR LE CONSTRUCTEUR
 AUTO'S MET DOOR DE FABRIKANT VOORZIENE MONTAGEPUNTEN
 FELHELYEZÉS GYÁRTÓ ÁLTAL KIJELÖLT PONTRA
 SAMOCHODY Z PRZEWIDZIANYMI PUNKTAMI UMOCOWANIA
 MODELI Z PREDVIDENIM LEŽIŠ-EM S STRANI PROIZVAJALCA

MODELLI AUTO	ANTERIORE	POSTERIORE
CARS	FRONT	REAR
COCHES	DELANTERO	TRASERO
WAGEN	VORDERE	HINTERE
VOITURES	AVANT	ARRIERE
AUTO	VOORSTE G.	ACHTERSTE G.
AUTÓ TIPUS	ELSŐ RÜD	HÁTSÓ RÜD
MODELI AVTOMOBILOV	PRZOD	TYL
	SPREDAJ	ZADAJ

ALFA 145	T	Z
ALFA 146	T	Z
ALFA 164	T	Z
ALFA 156	T	Z
ALFA 156 SW NO RAILINGS	T	Z

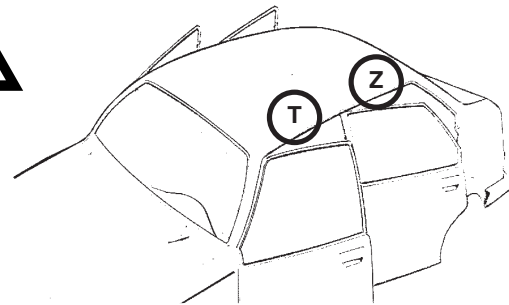
AVVITARE
 TO SCREW
 APRETAR
 FESTSCHRAUBEN
 VISSER
 VASTSCHROEVEN
 MEGHÚZNI
 WKRECIC
 PRIVITI

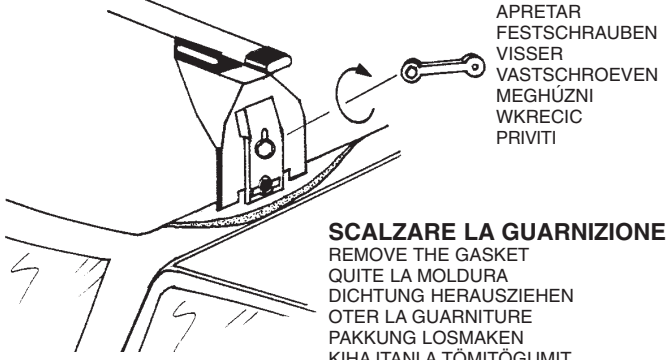

SCALZARE LA GUARNIZIONE
 REMOVE THE GASKET
 QUITE LA MOLDURA
 DICHTUNG HERAUSZIEHEN
 OTER LA GUARNITURE
 PAKKUNG LOSMAKEN
 KIHAJTANI A TÖMITÖGUMIT
 WYCIAGNAC USZCZELKE
 ODMAKNITI TESNILO

7

MODELLI CON PREDISPOSIZIONE DELLA CASA AUTO:
 CARS WITH PRE-EXISTING FIXING POINT FROM MANUFACTURER
 MODELOS CON PREDISPOSICION DEL FABRICANTE
 AUTOS MIT VOM HERSTELLER VORGESEHENE BEFESTIGUNGSPUNKTE
 VOITURES AVEC POINTS DE FIXAGE PREVUS PAR LE CONSTRUCTEUR
 AUTO'S MET DOOR DE FABRIKANT VOORZIENE MONTAGEPUNTEN
 FELHELYEZÉS GYÁRTÓ ÁLTAL KIJELÖLT PONTRA
 SAMOCHODY Z PRZEWIDZIANYMI PUNKTAMI UMOCOWANIA
 MODELI Z PREDVIDENIM LEŽIŠ-EM S STRANI PROIZVAJALCA

MODELLI AUTO	ANTERIORE	POSTERIORE
CARS	FRONT	REAR
COCHES	DELANTERO	TRASERO
WAGEN	VORDERE	HINTERE
VOITURES	AVANT	ARRIERE
AUTO	VOORSTE G.	ACHTERSTE G.
AUTÓ TIPUS	ELSŐ RÜD	HÁTSÓ RÜD
MODELI AVTOMOBILOV	PRZOD	TYL
	SPREDAJ	ZADAJ

BMW Serie 3 (91 ->98)	T	Z
-----------------------	---	---

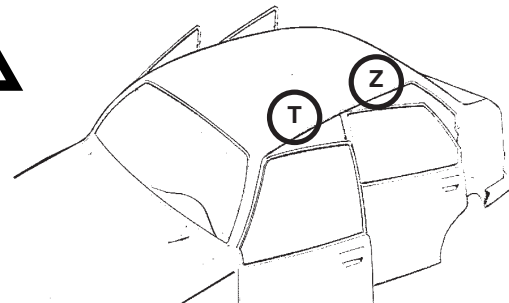
AVVITARE
 TO SCREW
 APRETAR
 FESTSCHRAUBEN
 VISSER
 VASTSCHROEVEN
 MEGHÚZNI
 WKRECIC
 PRIVITI

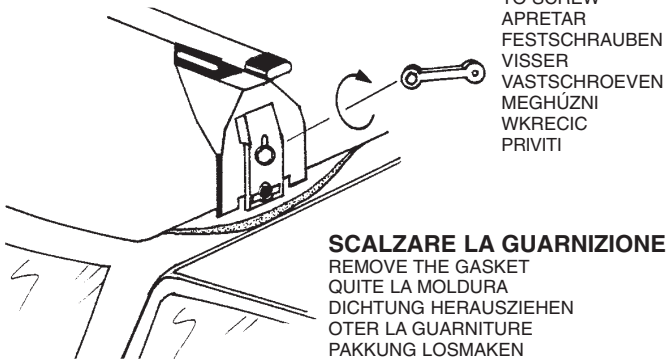

SCALZARE LA GUARNIZIONE
 REMOVE THE GASKET
 QUITE LA MOLDURA
 DICHTUNG HERAUSZIEHEN
 OTER LA GUARNITURE
 PAKKUNG LOSMAKEN
 KIHAJTANI A TÖMITÖGUMIT
 WYCIAGNAC USZCZELKE
 ODMAKNITI TESNILO



MODELLI CON PREDISPOSIZIONE DELLA CASA AUTO:

CARS WITH PRE-EXISTING FIXING POINT FROM MANUFACTURER
 MODELOS CON PREDISPOSICION DEL FABRICANTE
 AUTOS MIT VOM HERSTELLER VORGESEHENE BEFESTIGUNGSPUNKTE
 VOITURES AVEC POINTS DE FIXAGE PREVUS PAR LE CONSTRUCTEUR
 AUTO'S MET DOOR DE FABRIKANT VOORZIENE MONTAGEPUNTEN
 FELHELYEZÉS GYÁRTÓ ÁLTAL KIJELÖLT PONTRA
 SAMOCHODY Z PRZEWDZIANYMI PUNKTAMI UMOCOWANIA
 MODELI Z PREDVIDENIM LEŽIŠ»EM S STRANI PROIZVAJALCA

**8****MODELLI AUTO**

CARS
 COCHES
 WAGEN
 VOITURES
 AUTO
 AUTÓ TIPUS
 MODELI AVTOMOBILOV

ANTERIORE	POSTERIORE
FRONT	REAR
DELANTERO	TRASERO
VORDERE	HINTERE
AVANT	ARRIERE
VOORSTE G.	ACHTERSTE G.
ELSŐ RÜD	HÁTSO RÜD
PRZOD	TYL
SPREDAJ	ZADAJ

OPEL VECTRA 4-5P (88->01) T Z

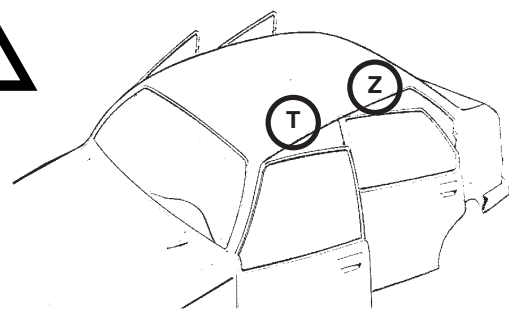
**SCALZARE LA GUARNIZIONE**

REMOVE THE GASKET
 QUITE LA MOLDURA
 DICHTUNG HERAUSZIEHEN
 OTER LA GUARNITURE
 PAKKUNG LOSMAKEN
 KIHAJTANI A TÖMITÖGUMIT
 WYCIAGNAC USZCZELKE
 ODMAKNITI TESNILO

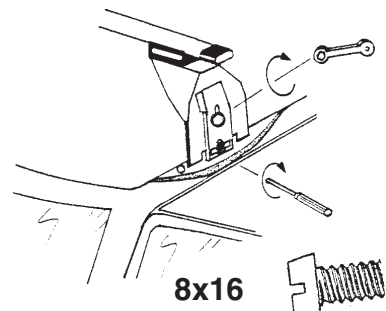
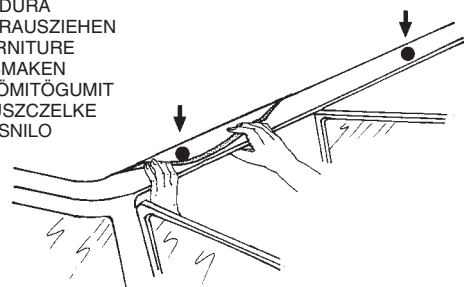

AVVITARE
 TO SCREW
 APRETAR
 FESTSCHRAUBEN
 VISSER
 VASTSCHROEVEN
 MEGHÚZNI
 WKRECIC
 PRIVITI

8x16

MODELLI CON PREDISPOSIZIONE DELLA CASA AUTO:

CARS WITH PRE-EXISTING FIXING POINT FROM MANUFACTURER
 MODELOS CON PREDISPOSICION DEL FABRICANTE
 AUTOS MIT VOM HERSTELLER VORGESEHENE BEFESTIGUNGSPUNKTE
 VOITURES AVEC POINTS DE FIXAGE PREVUS PAR LE CONSTRUCTEUR
 AUTO'S MET DOOR DE FABRIKANT VOORZIENE MONTAGEPUNTEN
 FELHELYEZÉS GYÁRTÓ ÁLTAL KIJELÖLT PONTRA
 SAMOCHODY Z PRZEWDZIANYMI PUNKTAMI UMOCOWANIA
 MODELI Z PREDVIDENIM LEŽIŠ»EM S STRANI PROIZVAJALCA

**9****MODELLI AUTO**

CARS
 COCHES
 WAGEN
 VOITURES
 AUTO
 AUTÓ TIPUS
 MODELI AVTOMOBILOV

ANTERIORE	POSTERIORE
FRONT	REAR
DELANTERO	TRASERO
VORDERE	HINTERE
AVANT	ARRIERE
VOORSTE G.	ACHTERSTE G.
ELSŐ RÜD	HÁTSO RÜD
PRZOD	TYL
SPREDAJ	ZADAJ

LANCIA THEMA T Z
 FIAT CROMA T Z
 SAAB 9000 - 900 5P (93 ->) - 9 - 5 T Z

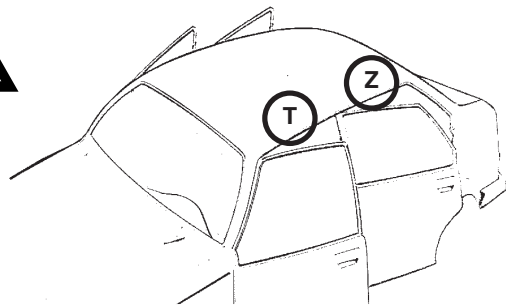
**SCALZARE LA GUARNIZIONE**

REMOVE THE GASKET
 QUITE LA MOLDURA
 DICHTUNG HERAUSZIEHEN
 OTER LA GUARNITURE
 PAKKUNG LOSMAKEN
 KIHAJTANI A TÖMITÖGUMIT
 WYCIAGNAC USZCZELKE
 ODMAKNITI TESNILO

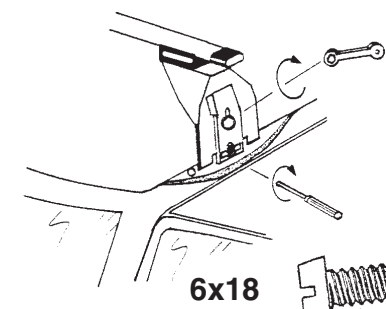
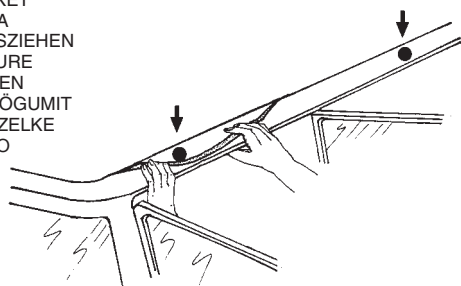

AVVITARE
 TO SCREW
 APRETAR
 FESTSCHRAUBEN
 VISSER
 VASTSCHROEVEN
 MEGHÚZNI
 WKRECIC
 PRIVITI

6x18

10**AVVITARE (A FONDO)**

TO SCREW (DOWN)
 APRETAR (A FONDO)
 FESTSCHRAUBEN
 VISSER (À FOND)
 VASTSCHROEVEN
 MEGHÚZNI
 WKRECIC DO KONCA
 PRIVITI (DO KONCA)

11**INSERIRE**

INSERT
 CUBRIR
 STOPFEN
 ENFILER
 BEVESTIG
 TOLJA FEL
 NALOZIC
 VSTAVITI.

12**INSERIRE**

INSERT
 CUBRIR
 STOPFEN
 ENFILER
 BEVESTIG
 TOLJA FEL
 NALOZIC
 VSTAVITI.