

(IT) Attenzione: Istruzioni di montaggio per barre in ferro.
(GB) Attention: Mounting instructions for steel bar carriers.
(E) Atención: Instrucciones de montaje para barras portatodo en hierro.
(D) Achtung: Montageanweisungen für Stahl-Lastenträger.
(F) Attention: Notices de montage pour barres de portage en métal.
(NL) Attentie: Handleiding voor dakdragers gemaakt van ijzer.
(P) Atenção: Instrukções de montagem para barras de tejadilho em ferro.
(H) Szerelési utasítás: acél tartórudakhoz.
(PL) Uwaga: Instrukcja montażu bagażników wykonanych ze stali.
(SLO) Pozor: Navodila za montažo o nosilceve prtljačnika -č eleznihi.
(HR) Uputstvo za: montažu u čeljeznih krovnih nosača.

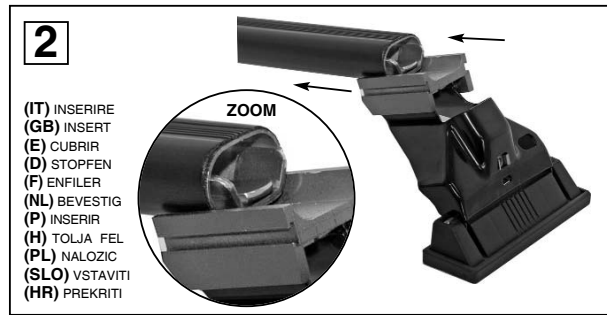

3

(IT) MODELLI AUTO (GB) CARS (E) COCHES (D) WAGEN (F) VOITURES	(NL) AUTO (P) MODELO AUTO (H) AUTO TIPUS (SLO) MODELI AVTOMOBILOV (HR) MODELI AUTA	(IT) ANTERIORE (GB) FRONT (E) DELANTERO (D) VORDERE (F) AVANT
FIAT BRAVA	80 mm.	80 mm.
FIAT MAREA	80 mm.	80 mm.
FIAT NEW PANDA (03->) No rails	36 mm.	43 mm.
TOYOTA AURIS 5P. (06->)	120 mm.	130 mm.

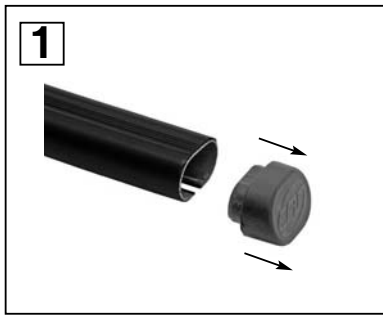
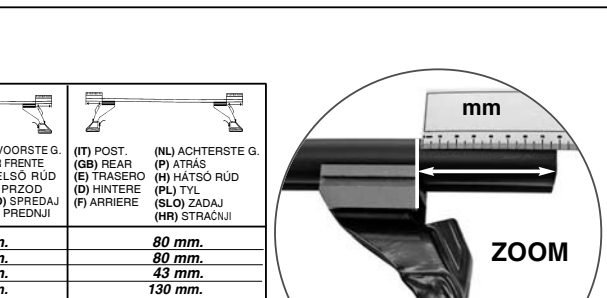

(IT) MISURE PRECISE
(GB) EXACT DIMENSIONS
(E) MEDIDAS CORRECTAS
(D) GENAUE MASSE
(F) MESURES EXACTES
(NL) EXACTE AFMETINGEN
(P) MEDIDAS PRECISAS
(H) PONTOS MÉRET
(PL) DOKŁADNE WYMIARY
(SLO) TO-NĚ MĚRE
(HR) PRECIZNE MJERE

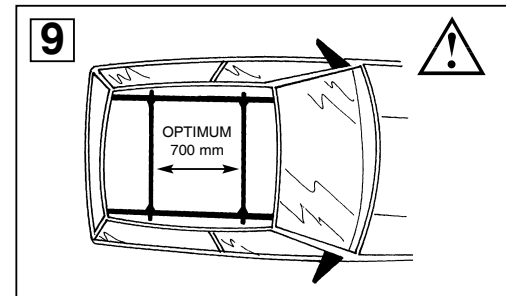
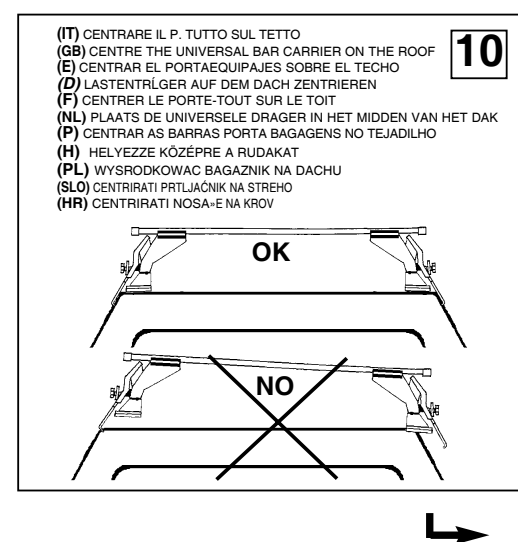
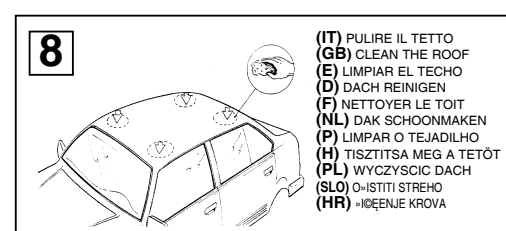
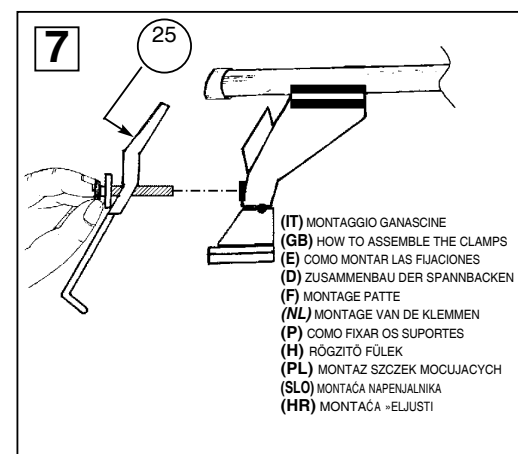
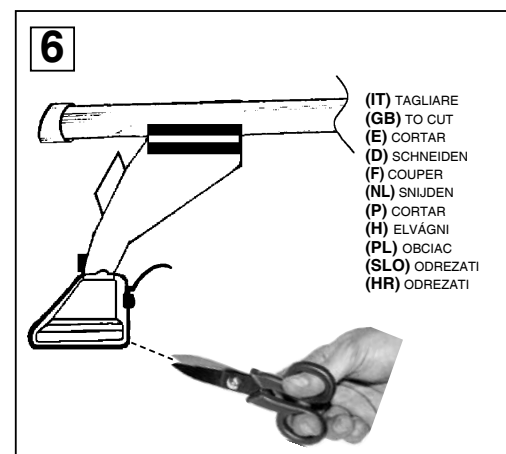
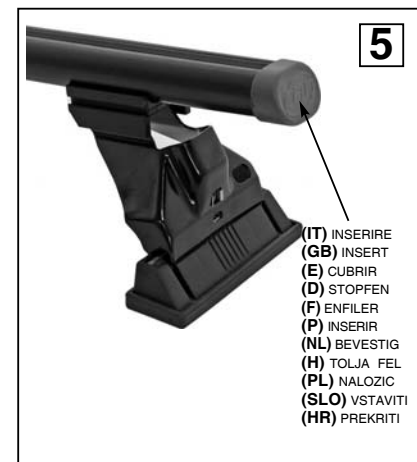
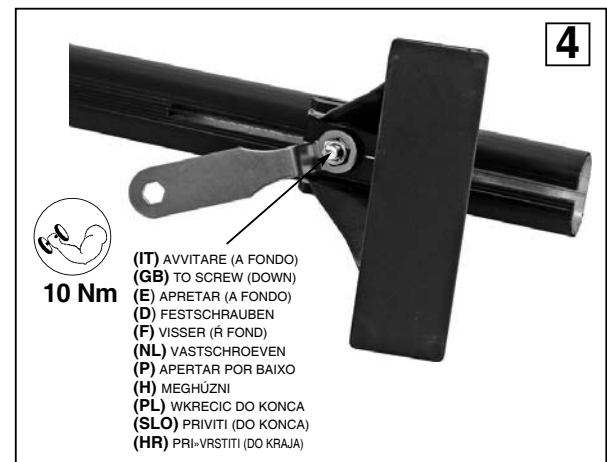

(IT) MODELLI CON PREDISPOSIZIONE DELLA CASA AUTO
 (GB) CARS WITH PRE-EXISTING FIXING POINT FROM MANUFACTURER
 (E) MODELOS CON PREDISPOSICION DEL FABRICANTE
 (D) AUTOS MIT VOM HERSTELLER VORGESEHENE BEFESTIGUNGSPUNKTE
 (F) VOITURES AVEC POINTS DE RÉPÔRE PREVUS PAR LE CONSTRUCTEUR
 (NL) AUTO'S MET DOOR DE FABRIKANT VOORZIENE MONTAGEPUNTEN
 (P) VIATURAS COM PONTOS DE FIXAÇÃO DO CONSTRUTOR PRÉ-EXISTENTES
 (H) FELHÉLYEZÉS GYÁRTÓ ÁLTAL KIJELÖLT PONTRA
 (PL) SAMOCHODY Z PRZEWDZIANYMI PUNKTAMI UMOCOWANIA
 (SLO) MODELI Z PREDVIDENIM LEČIŠ-EM S STRANI PROIZVAJALCA
 (HR) TVORNI-KI PRIPREMLJENI MODELI

"À TROUVER SUR LE BATTANT DE LA PORTE OU
 DANS LE MANUAL TECHNIQUE DE LA VOITURE "

11

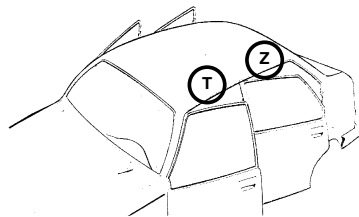

(IT) MODELLI AUTO	(IT) ANTERIORE	(IT) POSTERIORE
(GB) CARS	(GB) FRONT	(GB) REAR
(E) COCHES	(E) DELANTERO	(E) TRASERO
(D) WAGEN	(D) VORDERE	(D) HINTERE
(F) VOITURES	(F) AVANT	(F) ARRIERE
(NL) AUTO	(NL) VOORSTE G.	(NL) ACHTERSTE G.
(P) MODELO AUTO	(P) À FRENTE	(P) ATRÁS
(H) AUTÓ TIPUS	(H) ELSŐ RÚD	(H) HÁTSÓ RÚD
(SLO) MODELI AVTOMOBILOV	(SLO) SPREDAJ	(SLO) ZADAJ
(HR) MODELI AUTA	(HR) PREDNJI	(HR) STRAČNJI

FIAT BRAVA	T	Z
TOYOTA AURIS 5P. (06->)	T	Z

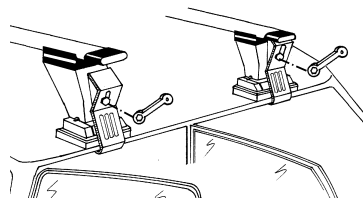

(IT) AVVITARE
 (GB) TO SCREW
 (E) APRETAR
 (D) FESTSCHRAUBEN
 (F) VISSER
 (NL) VASTSCHROEVEN
 (P) APERTAR
 (H) MEGHÚZNI
 (PL) WKRECIC
 (SLO) PRIVITI
 (HR) PRI-VRSTITI

(IT) MODELLI SENZA PREDISPOSIZIONE DELLA CASA AUTO
 (GB) CARS WITHOUT PRE-EXISTING FIXING POINT
 (E) PARA COCHES SIN PREDISPOSICION DEL FABRICANTE
 (D) AUTOS OHNE VOM HERSTELLER VORGESEHENE BEFESTIGUNGSPUNKTE
 (F) VOITURES SANS POINTS DE RÉPÔRE PRÉVUS PAR LE CONSTRUCTEUR
 (NL) AUTO'S ZONDER DOOR DE FABRIKANT VOORZIENE BEVESTIGINGSPUNTEN
 (P) VIATURAS SEM PONTOS DE FIXAÇÃO DO CONSTRUTOR PRÉ-EXISTENTES
 (H) FELHÉLYEZÉS GYÁRI JELÖLÉS NÉLKÜLI AUTÓKRA
 (PL) SAMOCHODY BEZ PRZEWDZIANYCH PUNKTOW UMOCOWANIA
 (SLO) MODELI Z NEPRVEDVIDENIM LEČIŠ-EM S STRANI PROIZVAJALCA
 (HR) TVORNI-KI NEPRIPREMLJENI MODELI

12



T mm. Z mm.

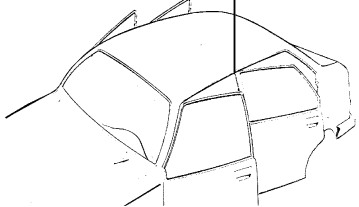

(IT) MODELLI AUTO	(IT) ANTERIORE	(IT) POSTERIORE
(GB) CARS	(GB) FRONT	(GB) REAR
(E) COCHES	(E) DELANTERO	(E) TRASERO
(D) WAGEN	(D) VORDERE	(D) HINTERE
(F) VOITURES	(F) AVANT	(F) ARRIERE
(NL) AUTO	(NL) VOORSTE G.	(NL) ACHTERSTE G.
(P) MODELO AUTO	(P) À FRENTE	(P) ATRÁS
(H) AUTÓ TIPUS	(H) ELSŐ RÚD	(H) HÁTSÓ RÚD
(SLO) MODELI AVTOMOBILOV	(SLO) SPREDAJ	(SLO) ZADAJ
(HR) MODELI AUTA	(HR) PREDNJI	(HR) STRAČNJI

FIAT MAREA	T (170 mm.)	Z (430 mm.)
FIAT NEW PANDA (03->) No rails	T (200 mm.)	Z (500 mm.)

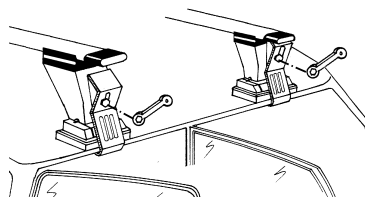

(IT) AVVITARE
 (GB) TO SCREW
 (E) APRETAR
 (D) FESTSCHRAUBEN
 (F) VISSER
 (NL) VASTSCHROEVEN
 (P) APERTAR
 (H) MEGHÚZNI
 (PL) WKRECIC
 (SLO) PRIVITI
 (HR) PRI-VRSTITI

