

Attenzione: Istruzioni di montaggio per barre in ferro.
Attention: Notices de montage pour barres de portage en fer.
Attention: Mounting instructions for bar-carriers made of iron.
Atencion: Instrucciones de montaje para barras portatodo en hierro.
Achtung: Montageanweisungen fuer lastentraeger aus eisen.
Attentie: Handleiding voor dakdragers gemaakt van ijzer.
Uwaga: Instrukcja montażu bagażników wykonanych ze stali.
Pozor: Navodila za montažo nosilcev prtljažnika - železnih.
 Szerelési utasítás acél tartórudakhoz.

1

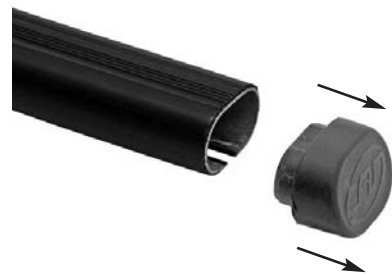

2

INSERIRE
 INSERT
 CUBRIR
 STOPFEN
 ENFILER
 BEVESTIG
 TOLJA FEL
 NALOZIC
 VSTAVITI.

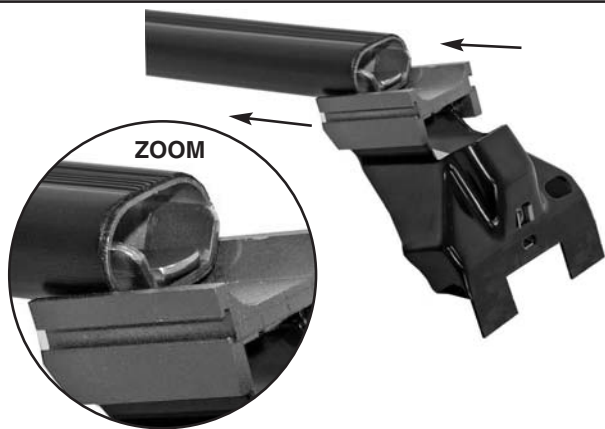

3



INSERIRE
 INSERT
 CUBRIR
 STOPFEN
 ENFILER
 BEVESTIG
 TOLJA FEL
 NALOZIC
 VSTAVITI.

4

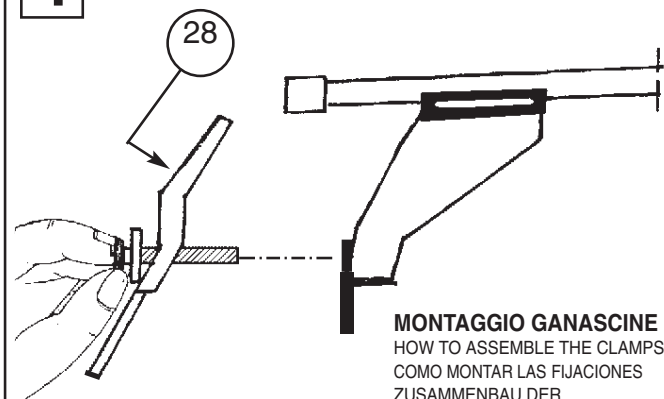

MONTAGGIO GANASCINE
 HOW TO ASSEMBLE THE CLAMPS
 COMO MONTAR LAS FIJACIONES
 ZUSAMMENBAU DER
 SPANNBACKEN
 MONTAGE CROCHET
 MONTAGE VAN DE KLEMMEN
 RÖGZITŐ FÜLEK
 MONTAZ SZCZEK MOCUJACYCH
 MONTAŽA NAPENJALNIKA

5

CENTRARE IL P. TUTTO SUL TETTO
 CENTRE THE UNIVERSAL BAR CARRIER ON THE ROOF
 CENTRAR EL PORTAEQUIPAJES SOBRE EL TECHO
 LASTENTRÄGER AUF DEM DACH ZENTRIEREN
 CENTRER LE TOIT AVEC LE PORTE-TOUT
 PLAATS DE UNIVERSELE DRAGERIN HET MIDDEN VAN HET DAK
 HELYEZZE KÖZÉPRE A RUDAKAT
 WYSRODKOWAC BAGAŻNIK NA DACHU
 CENTRIRATI PRTLJAŽNIK NA STREHO

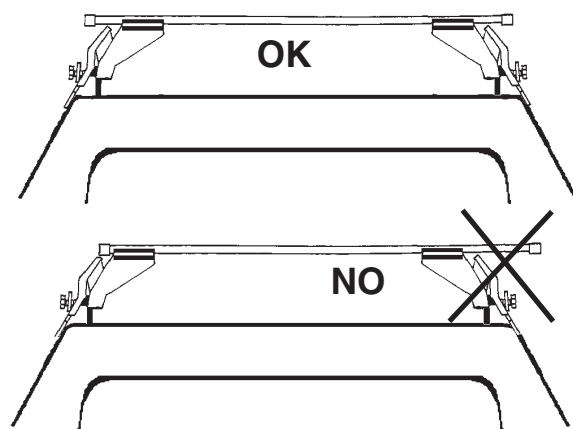

MODELLI CON PREDISPOSIZIONE DELLA CASA AUTO:
 CARS WITH PRE-EXISTING FIXING POINT FROM MANUFACTURER
 MODELOS CON PREDISPOSICION DEL FABRICANTE
 AUTOS MIT VOM HERSTELLER VORGESEHENE BEFESTIGUNGSPUNKTE
 VOITURES AVEC POINTS DE FIXAGE PREVUS PAR LE CONSTRUCTEUR
 AUTO'S MET DOOR DE FABRIKANT VOORZIENE MONTAGEPUNTEN
 FELHELYEZÉS GYÁRTÓ ÁLTAL KIJELÖLT PONTRA
 SAMOCHODY Z PRZEWDZIANYMI PUNKTAMI UMOCOWANIA
 MODELI Z PREDVIDENIM LEŽIŠ»EM S STRANI PROIZVAJALCA

MODELLI AUTO
 CARS
 COCHES
 WAGEN
 VOITURES
 AUTO
 AUTÓ TIPUS
 MODELI AVTOMOBILOV

ANTERIORE
 FRONT
 DELANTERO
 VORDERE
 AVANT
 VOORSTE G.
 ELSŐ RÚD
 PRZOD
 SPREDAJ

POSTERIORE
 REAR
 TRASERO
 HINTERE
 ARRIERE
 ACHTERSTE G.
 HÁTSÓ RÚD
 TYL
 ZADAJ

ALFA 155	T	Z
FIAT TIPO 3-5P	T	Z
FIAT PUNTO 5P (->98)	T	Z
FIAT TEMPRA 4P	T	Z



6

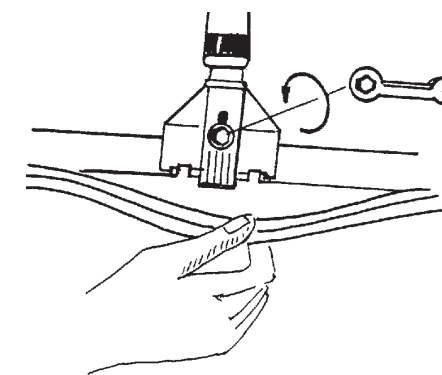
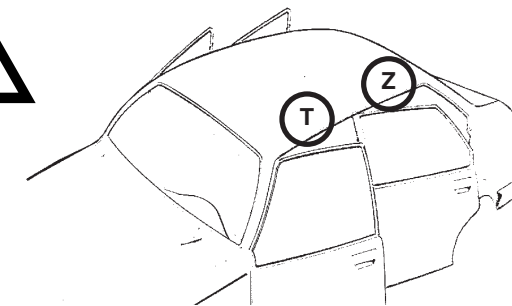

AVVITARE
 TO SCREW
 APRETAR
 FESTSCHRAUBEN
 VISSER
 VASTSCHROEVEN
 MEGHÚZNI
 WKRECIC
 PRIVITI

MODELLI CON PREDISPOSIZIONE DELLA CASA AUTO:
 CARS WITH PRE-EXISTING FIXING POINT FROM MANUFACTURER
 MODELOS CON PREDISPOSICION DEL FABRICANTE
 AUTOS MIT VOM HERSTELLER VORGESEHENE BEFESTIGUNGSPUNKTE
 VOITURES AVEC POINTS DE FIXAGE PREVUS PAR LE CONSTRUCTEUR
 AUTO'S MET DOOR DE FABRIKANT VOORZIENE MONTAGEPUNTEN
 FELHELYEZÉS GYÁRTÓ ÁLTAL KIJELÖLT PONTRA
 SAMOCHODY Z PRZEWDZIANYMI PUNKTAMI UMOCOWANIA
 MODELI Z PREDVIDENIM LEŽIŠ»EM S STRANI PROIZVAJALCA

MODELLI AUTO
 CARS
 COCHES
 WAGEN
 VOITURES
 AUTO
 AUTÓ TIPUS
 MODELI AVTOMOBILOV

ANTERIORE
 FRONT
 DELANTERO
 VORDERE
 AVANT
 VOORSTE G.
 ELSŐ RÚD
 PRZOD
 SPREDAJ

POSTERIORE
 REAR
 TRASERO
 HINTERE
 ARRIERE
 ACHTERSTE G.
 HÁTSÓ RÚD
 TYL
 ZADAJ

LANCIA DEDRA (93 ->)	T	Z
LANCIA DELTA 3-5P (93 ->96)	T	Z



7

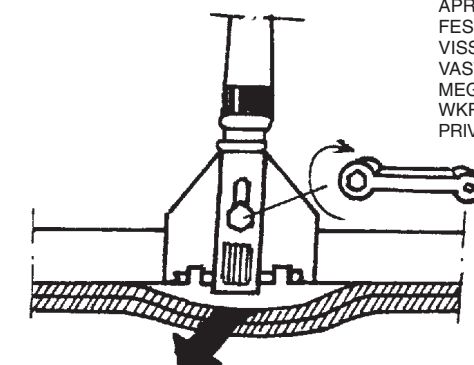
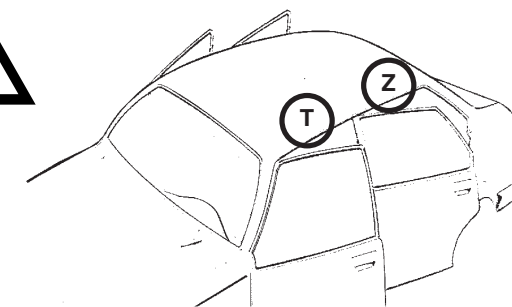

AVVITARE
 TO SCREW
 APRETAR
 FESTSCHRAUBEN
 VISSER
 VASTSCHROEVEN
 MEGHÚZNI
 WKRECIC
 PRIVITI

SVITARE
 UNSCREW
 AFLOJAR
 ABSCHRAUBEN
 DEVISSER
 OPENSCHROEVEN
 KICSAVARNI
 WYKRECIC
 ODVITI

SCALZARE LA GUARNIZIONE
 REMOVE THE GASKET
 QUITE LA MOLDURA
 DICHTUNG HERAUSZIEHEN
 OTER LA GUARNITURE
 PAKKUNG LOSMAKEN
 KIHAJTANI A TÖMITÖGUMIT
 WYCIAGNAC USZCZELKE
 ODMAKNITI TESNILO



8



AVVITARE (A FONDO)

TO SCREW (DOWN)
APRETAR (A FONDO)
FESTSCHRAUBEN
VISSER (À FOND)
VASTSCHROEVEN
MEGHÚZNI
WKRECIC DO KONCA
PRIVITI (DO KONCA)

9



INSERIRE

INSERT
CUBRIR
STOPFEN
ENFILER
BEVESTIG
TOLJA FEL
NALOZIC
VSTAVITI.

10



INSERIRE

INSERT
CUBRIR
STOPFEN
ENFILER
BEVESTIG
TOLJA FEL
NALOZIC
VSTAVITI.