

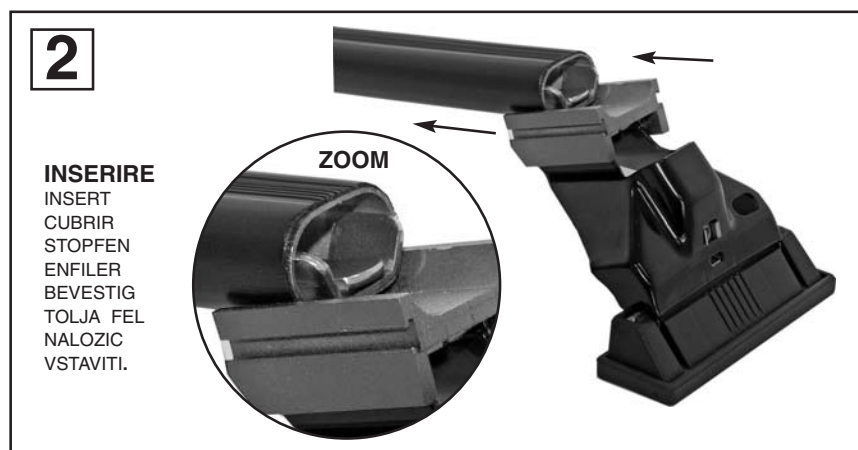

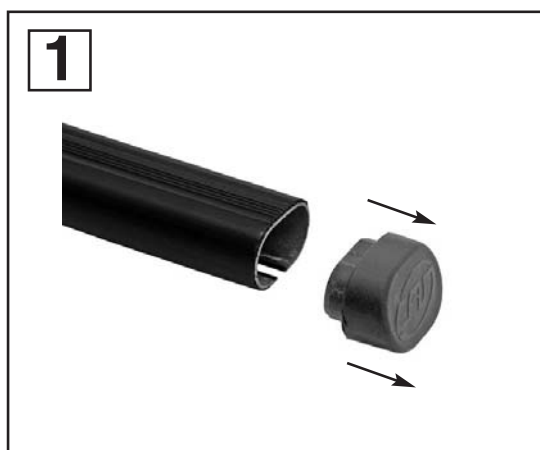

**Attenzione:** Istruzioni di montaggio per barre in ferro.  
**Attention:** Notices de montage pour barres de portage en fer.  
**Attention:** Mounting instructions for bar-carriers made of iron.  
**Atencion:** Instrucciones de montaje para barras portatodo en hierro.  
**Achtung:** Montageanweisungen fuer lastentraeger aus eisen.  
**Attentie:** Handleiding voor dakdragers gemaakt van ijzer.  
**Uwaga:** Instrukcja montażu bagażników wykonanych ze stali.  
**Pozor:** Navodila za montažo nosilcev prtljažnika - železnih.  
 Szerelési utasítás acél tartórudakhoz.



**3**

 <b>MODELLI AUTO / CARS / COCHES / WAGEN / VOITURES / AUTO / AUTÓ TIPUS / MODELI AVTOMOBILOV.</b>	 <b>ANTERIORE</b> FRONT DELANTERO VORDERE	 <b>POSTERIORE</b> REAR TRASERO HINTERE	 ARRIERE ACHTERSTE G. HÁTSÓ RÜD TYL ZADAJ
	DAEWOO ESPERO SUZUKI SWIFT 5P (96->)	75 mm. 127 mm.	90 mm. 130 mm.

**ZOOM**

**MISURE PRECISE**  
 EXACT DIMENSIONS  
 MEDIDAS CORRECTAS  
 GENAUE MASSE  
 MESURES EXACTES  
 EXACTE AFMETINGEN  
 PONTOS MÉRET  
 DOKŁADNE WYMIARY  
 TO» NE MERE

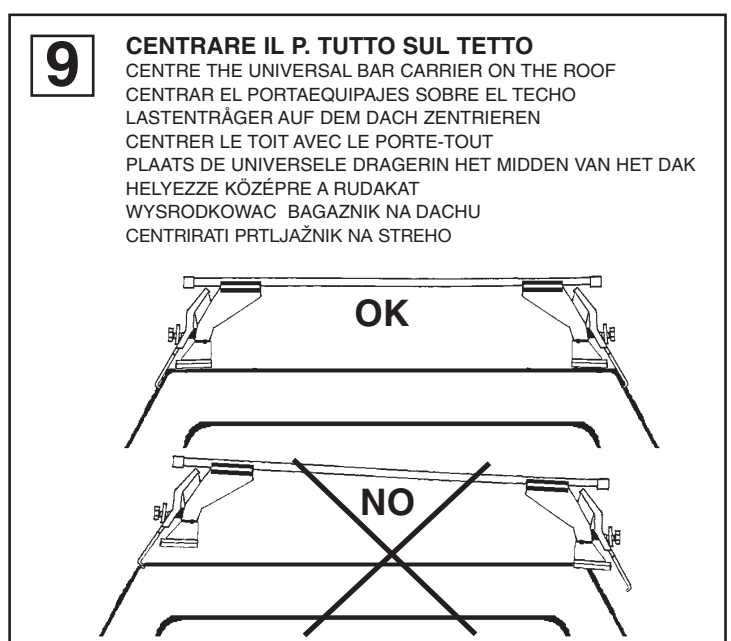
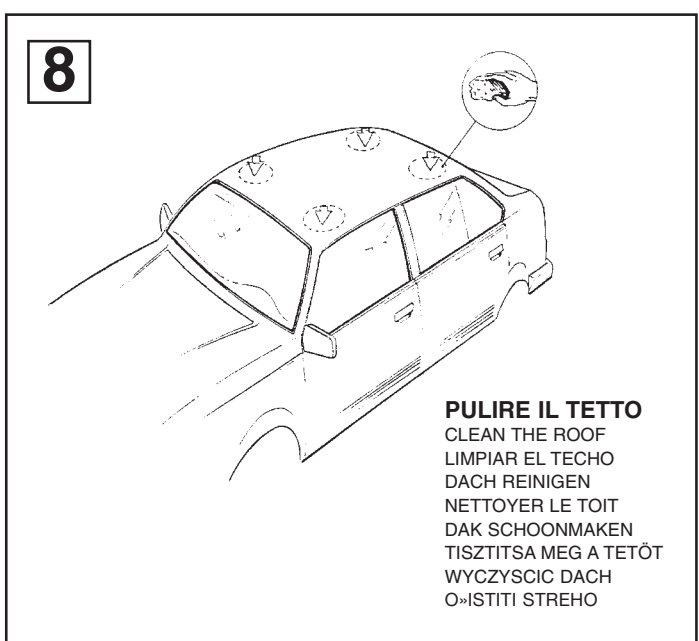
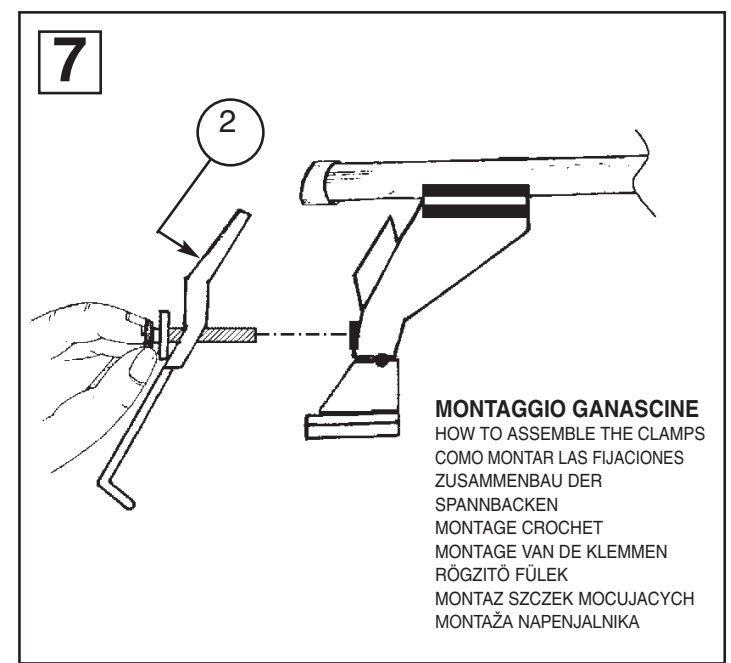
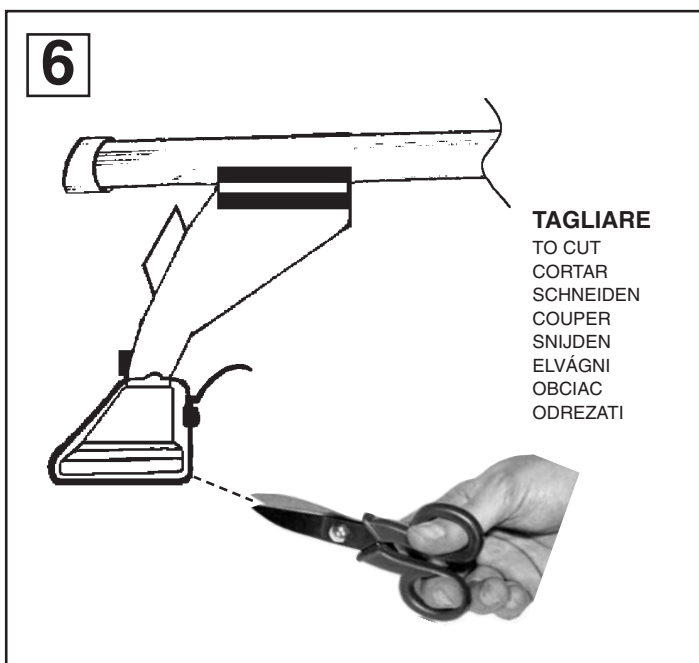
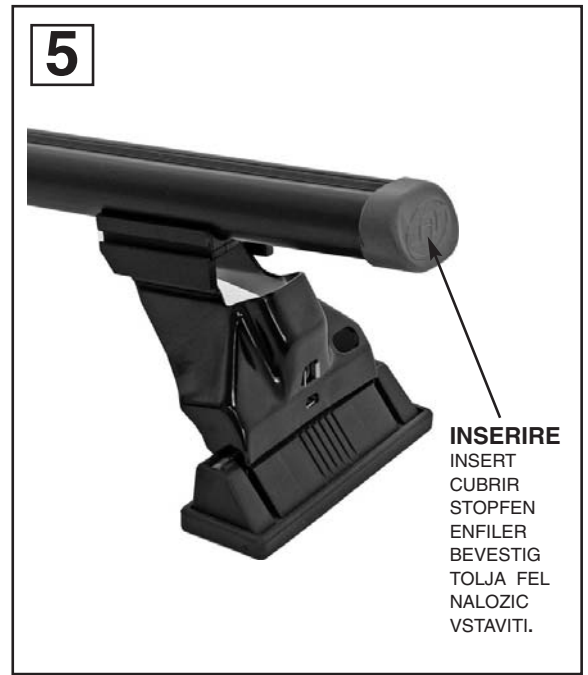
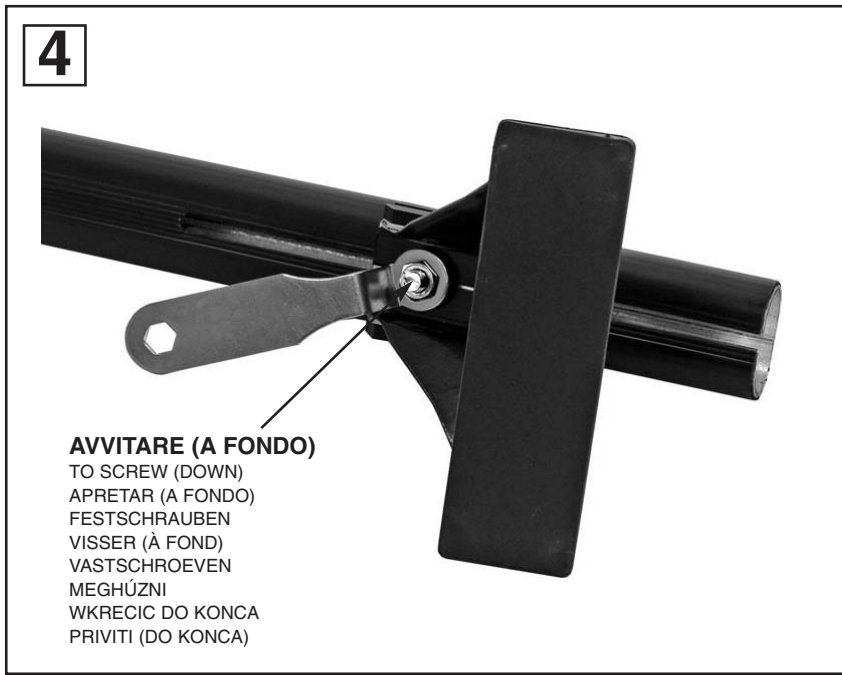

**MODELLI SENZA PREDISPOSIZIONE DELLA CASA AUTO:**

CARS WITHOUT PRE-EXISTING FIXING POINT  
 PARA COCHES SIN PREDISPOSICION DEL FABRICANTE  
 AUTOS OHNE VOM HERSTELLER VORGESEHENE BEFESTIGUNGSPUNKTE  
 VOITURES SANS POINTS DE FIXAGE PRÉVUS PAR LE CONSTRUCTEUR  
 AUTO'S ZONDER DOOR DE FABRIKANT VOORZIENE BEVESTIGINGSPUNTEN  
 FELHÉLYEZÉS GYÁRI JELŐLÉS NÉLKÜLI AUTÓKRA  
 SAMOCHODY BEZ PRZEWIDZIANYCH PUNKTOW UMOCOWANIA  
 MODELI Z NEPREDVIDENIM LEŽIŠ-EM S STRANI PROIZVAJALCA

**10****MODELLI AUTO**

CARS  
 COCHES  
 WAGEN  
 VOITURES  
 AUTO  
 AUTÓ TIPUS  
 MODELI AVTOMOBILOV

ANTERIORE	POSTERIORE
FRONT	REAR
DELANTERO	TRASERO
VORDERE	HINTERE
AVANT	ARRIERE
VOORSTE G.	ACHTERSTE G.
ELSŐ RÜD	HÁTSÓ RÜD
PRZOD	TYL
SPREDAJ	ZADAJ

**T****Z**

DAEWOO ESPERO	270 mm.	340 mm.
SUZUKI SWIFT 5P (96->)	250 mm.	420 mm.

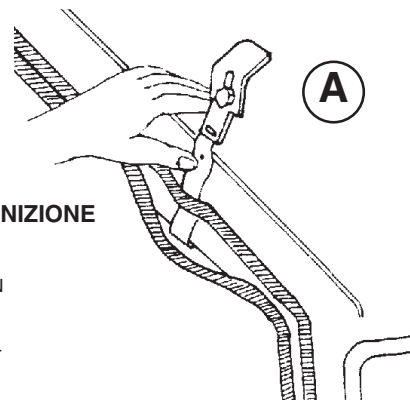
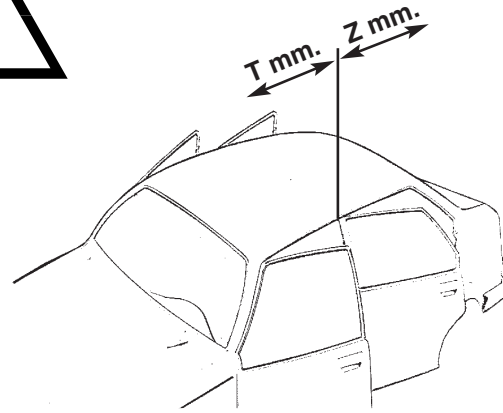
**SCALZARE LA GUARNIZIONE**

REMOVE THE GASKET  
 QUITE LA MOLDURA  
 DICHTUNG HERAUSZIEHEN  
 OTER LA GUARNITURE  
 PAKKUNG LOSMAKEN  
 KIHAJTANI A TÖMITŐGUMIT  
 WYCIAGNAC USZCZELKE  
 ODMAKNITI TESNILO

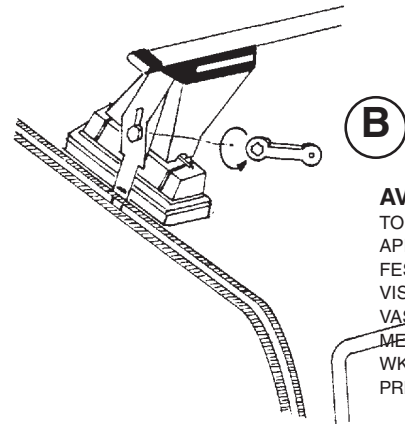
**B****AVVITARE**

TO SCREW  
 APRETAR  
 FESTSCHRAUBEN  
 VISSER  
 VASTSCHROEVEN  
 MEGHÚZNI  
 WKRECIC  
 PRIVITI

**11****INSERIRE**

INSERT  
 CUBRIR  
 STOPFEN  
 ENFILER  
 BEVESTIG  
 TOLJA FEL  
 NALOZIC  
 VSTAVITI.

**12****INSERIRE**

INSERT  
 CUBRIR  
 STOPFEN  
 ENFILER  
 BEVESTIG  
 TOLJA FEL  
 NALOZIC  
 VSTAVITI.