

**Attenzione:** Istruzioni di montaggio per barre in ferro.  
**Attention:** Notices de montage pour barres de portage en fer.  
**Attention:** Mounting instructions for bar-carriers made of iron.  
**Atencion:** Instrucciones de montaje para barras portatodo en hierro.  
**Achtung:** Montageanweisungen fuer lastentraeger aus eisen.  
**Attentie:** Handleiding voor dakdragers gemaakt van ijzer.  
**Uwaga:** Instrukcja montażu bagażników wykonanych ze stali.  
**Pozor:** Navodila za montažo nosilcev prtljažnika - železnih.  
**Szerelési utasítás** acél tartórudakhoz.

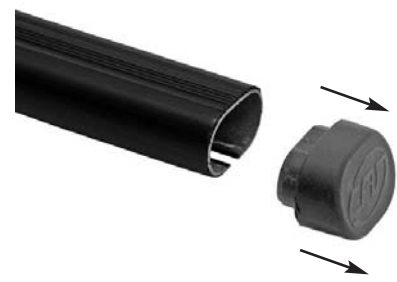

**1**



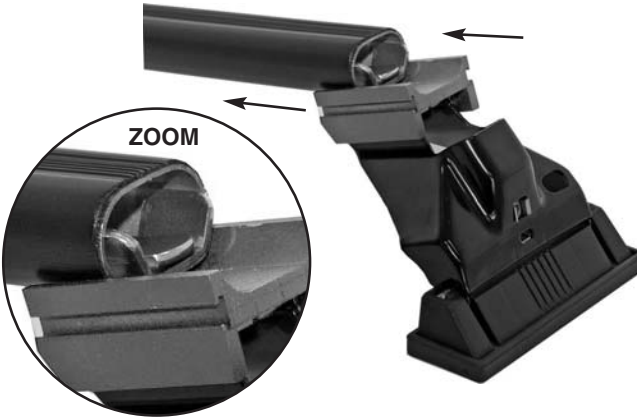

**2**

**INSERIRE**  
 INSERT  
 CUBRIR  
 STOPFEN  
 ENFILER  
 BEVESTIG  
 TOLJA FEL  
 NALOZIC  
 VSTAVITI.



**3**

		
<b>MODELLI AUTO / CARS / COCHES / WAGEN / VOITURES / AUTO / AUTÓ TIPUS / MODELI AVTOMOBILOV.</b>	<b>ANTERIORE</b> FRONT DELANTERO VORDERE	<b>POSTERIORE</b> REAR TRASERO HINTERE
<b>HYUNDAI ATOS PRIME Senza Rails</b>	59 mm.	67 mm.
<b>HYUNDAI ATOS Senza Rails</b>	59 mm.	67 mm.
<b>TOYOTA AVENSIS VERSO (02)</b>	71 mm.	72 mm.

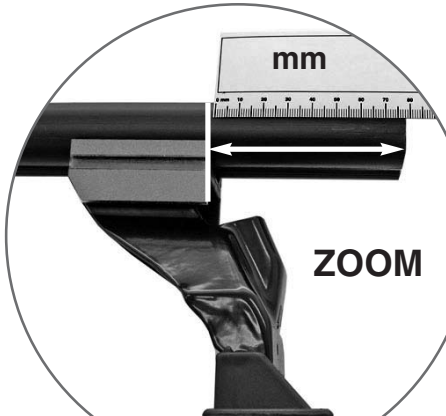



**MISURE PRECISE**  
 EXACT DIMENSIONS  
 MEDIDAS CORRECTAS  
 GENAUE MASSE  
 MESURES EXACTES  
 EXACTE AFMETINGEN  
 PONTOS MÉRET  
 DOKLADNE WYMIARY  
 TO» NE MERE

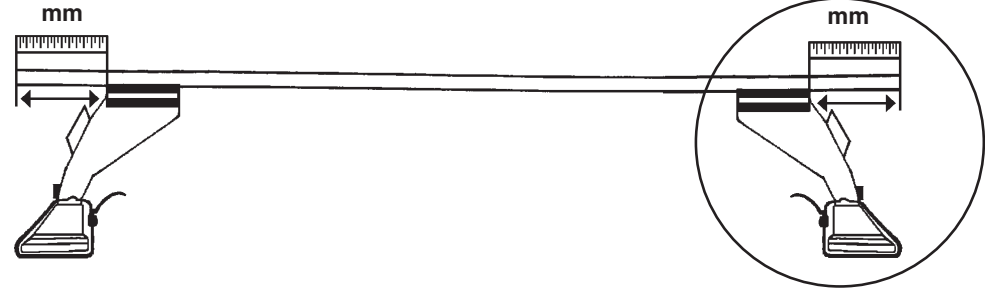

**4**

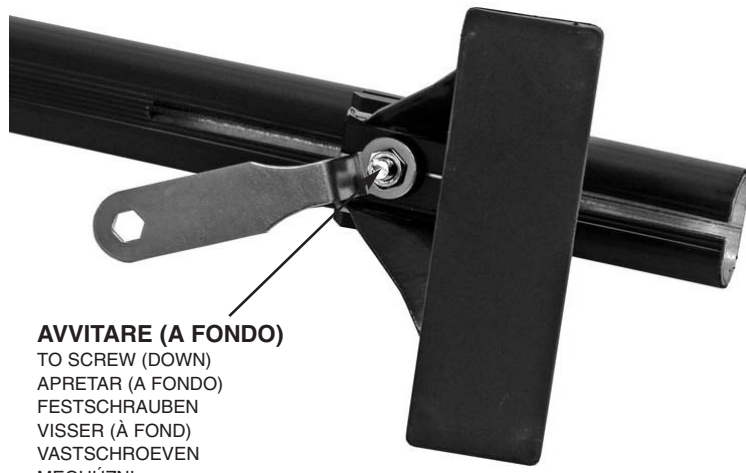

**AVVITARE (A FONDO)**  
 TO SCREW (DOWN)  
 APRETAR (A FONDO)  
 FESTSCHRAUBEN  
 VISSER (À FOND)  
 VASTSCHROEVEN  
 MEGHÚZNI  
 WKRECIC DO KONCA  
 PRIVITI (DO KONCA)

**5**



**INSERIRE**  
 INSERT  
 CUBRIR  
 STOPFEN  
 ENFILER  
 BEVESTIG  
 TOLJA FEL  
 NALOZIC  
 VSTAVITI.

**6**

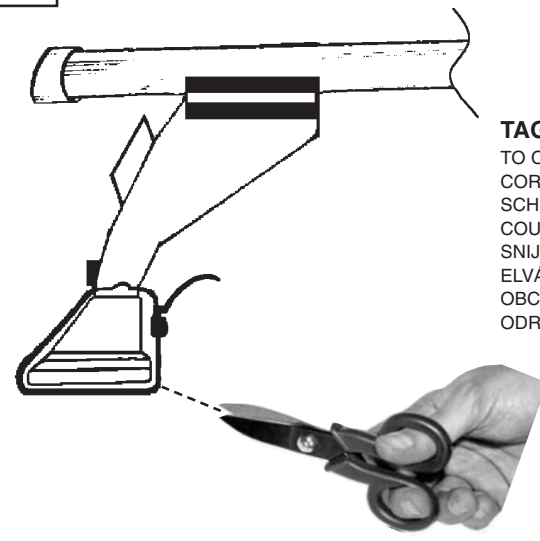

**TAGLIARE**  
 TO CUT  
 CORTAR  
 SCHNEIDEN  
 COUPER  
 SNIJDEN  
 ELVÁGNI  
 OBCIAC  
 ODREZATI

**7**

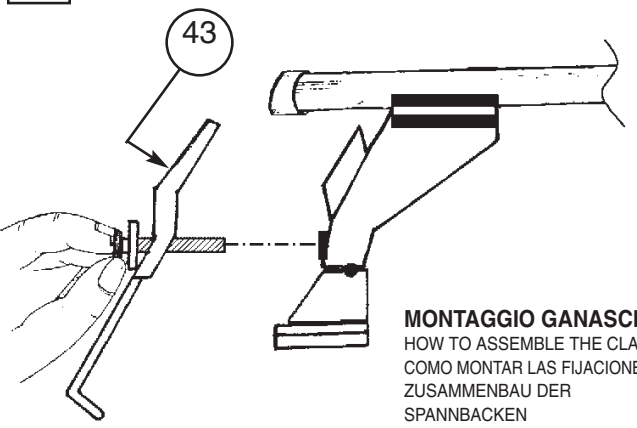

**MONTAGGIO GANASCINE**  
 HOW TO ASSEMBLE THE CLAMPS  
 COMO MONTAR LAS FIJACIONES  
 ZUSAMMENBAU DER SPANNBACKEN  
 MONTAGE CROCHET  
 MONTAGE VAN DE KLEMMEN  
 RÖGZITŐ FÜLEK  
 MONTAZ SZCZEK MOCUJACYCH  
 MONTAŽA NAPENJALNIKA

**8**

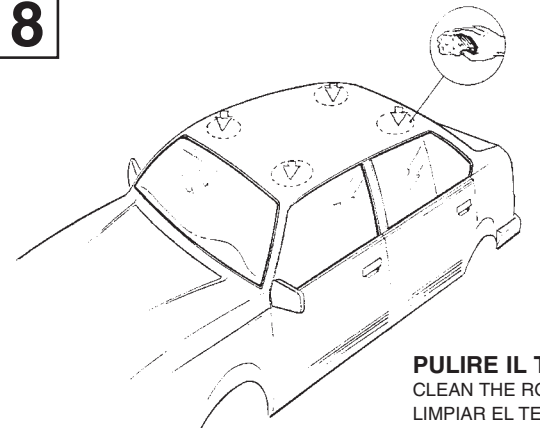

**PULIRE IL TETTO**  
 CLEAN THE ROOF  
 LIMPIAR EL TECHO  
 DACH REINIGEN  
 NETTOYER LE TOIT  
 DAK SCHOONMAKEN  
 TISZTÍTSA MEG A TETŐT  
 WYCZYSCIC DACH  
 O»ISTITI STREHO

**9**

**CENTRARE IL P. TUTTO SUL TETTO**  
 CENTRE THE UNIVERSAL BAR CARRIER ON THE ROOF  
 CENTRAR EL PORTAEQUIPAJES SOBRE EL TECHO  
 LASTENTRÄGER AUF DEM DACH ZENTRIEREN  
 CENTRER LE TOIT AVEC LE PORTE-TOUT  
 PLAATS DE UNIVERSELE DRAGERIN HET MIDDEN VAN HET DAK  
 HELYEZZE KÖZÉPRE A RUDAKAT  
 WYSRODKOWAC BAGAZNIK NA DACHU  
 CENTRIRATI PRTLJAŽNIK NA STREHO

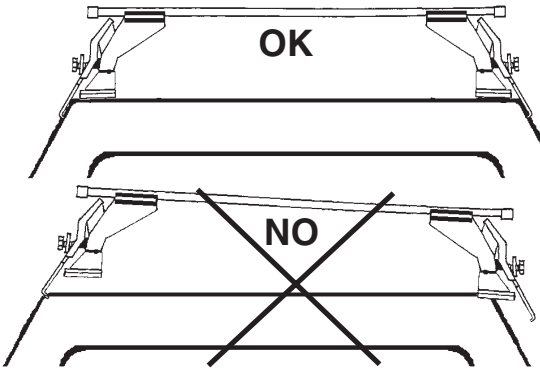



**MODELLI SENZA PREDISPOSIZIONE DELLA CASA AUTO:**

CARS WITHOUT PRE-EXISTING FIXING POINT  
 PARA COCHES SIN PREDISPOSICION DEL FABRICANTE  
 AUTOS OHNE VOM HERSTELLER VORGESEHENE BEFESTIGUNGSPUNKTE  
 VOITURES SANS POINTS DE FIXAGE PRÉVUS PAR LE CONSTRUCTEUR  
 AUTO'S ZONDER DOOR DE FABRIKANT VOORZIENE BEVESTIGINGSPUNTEN  
 FELHELYEZÉS GYÁRI JELŐLÉS NÉLKÜLI AUTÓKRA  
 SAMOCHODY BEZ PRZEWIDZIANYCH PUNKTOW UMOCOWANIA  
 MODELI Z NEPREDVIDENIM LEŽIŠ-EM S STRANI PROIZVAJALCA

**10****MODELLI AUTO**

CARS  
 COCHES  
 WAGEN  
 VOITURES  
 AUTO  
 AUTÓ TIPUS  
 MODELI AVTOMOBILOV

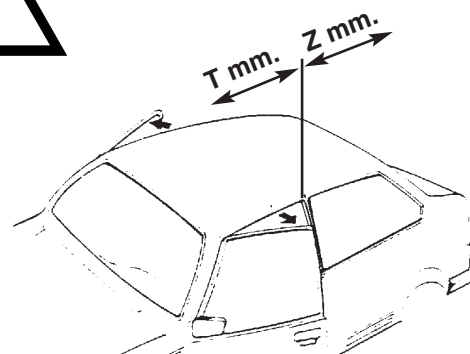
ANTERIORE	POSTERIORE
FRONT	REAR
DELANTERO	TRASERO
VORDERE	HINTERE
AVANT	ARRIERE
VOORSTE G.	ACHTERSTE G.
ELSŐ RÜD	HÁTÓSÓ RÜD
PRZOD	TYL
SPREDAJ	ZADAJ

**T****Z**

<b>HYUNDAI ATOS PRIME Senza Rails</b>	200 mm.	500 mm.
<b>HYUNDAI ATOS Senza Rails</b>	200 mm.	500 mm.

**AVVITARE**

TO SCREW  
 APRETAR  
 FESTSCHRAUBEN  
 VISSER  
 VASTSCHROEVEN  
 MEGHÚZNI  
 WKRECIC  
 PRIVITI

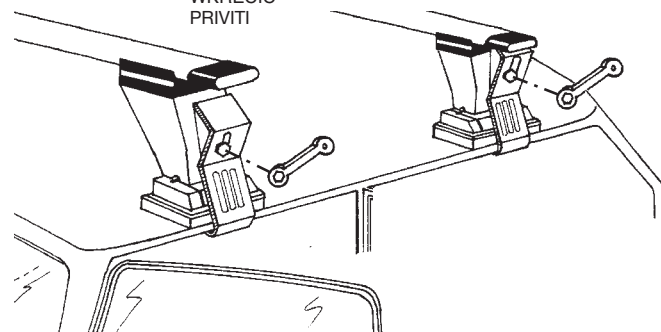
**12****INSERIRE**

INSERT  
 CUBRIR  
 STOPFEN  
 ENFILER  
 BEVESTIG  
 TOLJA FEL  
 NALOZIC  
 VSTAVITI.

**13****INSERIRE**

INSERT  
 CUBRIR  
 STOPFEN  
 ENFILER  
 BEVESTIG  
 TOLJA FEL  
 NALOZIC  
 VSTAVITI.

**MODELLI CON PREDISPOSIZIONE DELLA CASA AUTO:**

CARS WITH PRE-EXISTING FIXING POINT FROM MANUFACTURER  
 MODELOS CON PREDISPOSICION DEL FABRICANTE  
 AUTOS MIT VOM HERSTELLER VORGESEHENE BEFESTIGUNGSPUNKTE  
 VOITURES AVEC POINTS DE FIXAGE PRÉVUS PAR LE CONSTRUCTEUR  
 AUTO'S MET DOOR DE FABRIKANT VOORZIENE MONTAGEPUNTEN  
 FELHELYEZÉS GYÁRTÓ ÁLTAL KIJELÖLT PONTRA  
 SAMOCHODY Z PRZEWIDZIANYMI PUNKTAMI UMOCOWANIA  
 MODELI Z PREDVIDENIM LEŽIŠ-EM S STRANI PROIZVAJALCA

**11****MODELLI AUTO**

CARS  
 COCHES  
 WAGEN  
 VOITURES  
 AUTO  
 AUTÓ TIPUS  
 MODELI AVTOMOBILOV

ANTERIORE	POSTERIORE
FRONT	REAR
DELANTERO	TRASERO
VORDERE	HINTERE
AVANT	ARRIERE
VOORSTE G.	ACHTERSTE G.
ELSŐ RÜD	HÁTÓSÓ RÜD
PRZOD	TYL
SPREDAJ	ZADAJ

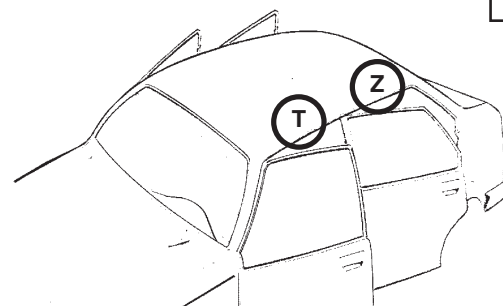
**T****Z****AVVITARE**

TO SCREW  
 APRETAR  
 FESTSCHRAUBEN  
 VISSER  
 VASTSCHROEVEN  
 MEGHÚZNI  
 WKRECIC  
 PRIVITI

