

Attenzione: Istruzioni di montaggio per barre in ferro.
Attention: Notices de montage pour barres de portage en fer.
Attention: Mounting instructions for bar-carriers made of iron.
Atencion: Instrucciones de montaje para barras portatodo en hierro.
Achtung: Montageanweisungen fuer lastentraeger aus eisen.
Attentie: Handleiding voor dakdragers gemaakt van ijzer.
Uwaga: Instrukcja montazu bagazników wykonanych ze stali.
Pozor: Navodila za montažo nosilcev prtljažnika - železnih.
 Szerelési utasítás acél tartórudakhoz.

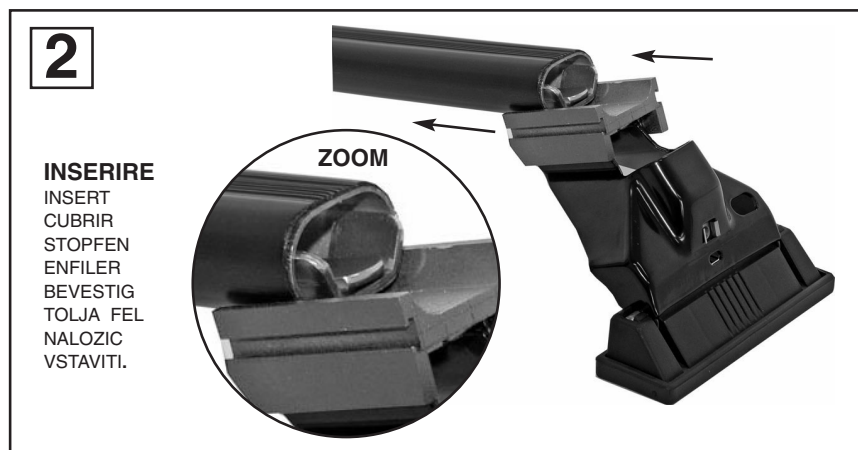
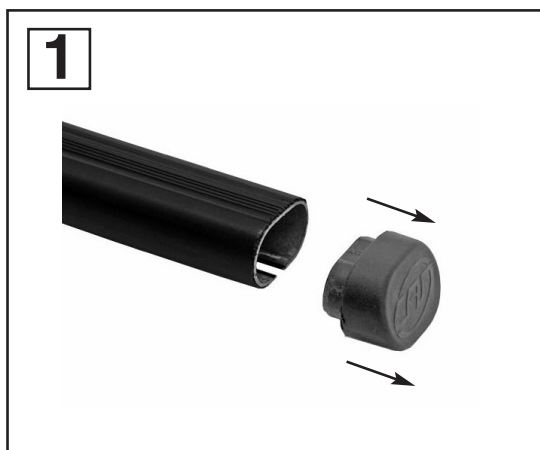

3

MODELLI AUTO / CARS / COCHES / WAGEN / VOITURES / AUTO / AUTÓ TIPUS / MODELI AVTOMOBILOV.	ANTERIORE FRONT DELANTERO VORDERE	POSTERIORE REAR TRASERO HINTERE	
ALFA ROMEO 147 3P	80 mm.	92 mm.	

MISURE PRECISE
 EXACT DIMENSIONS
 MEDIDAS CORRECTAS
 GENAUE MASSE
 MESURES EXACTES
 EXACTE AFMETINGEN
 PONTOS MÉRET
 DOKŁADNE WYMIARY
 TOČNE MERE

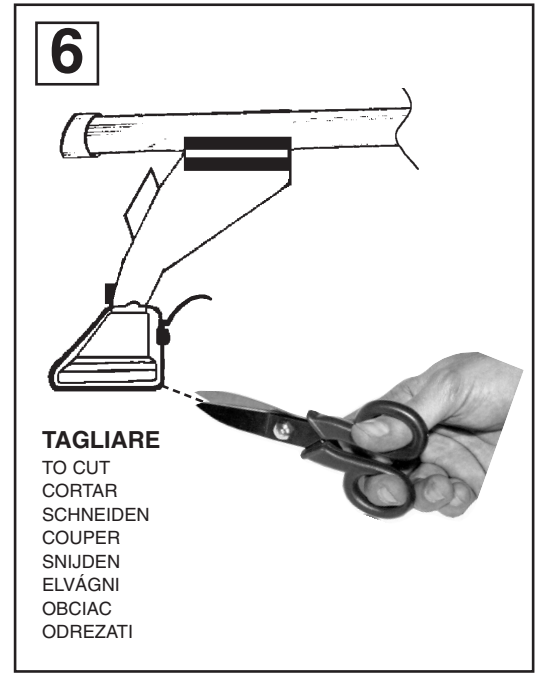
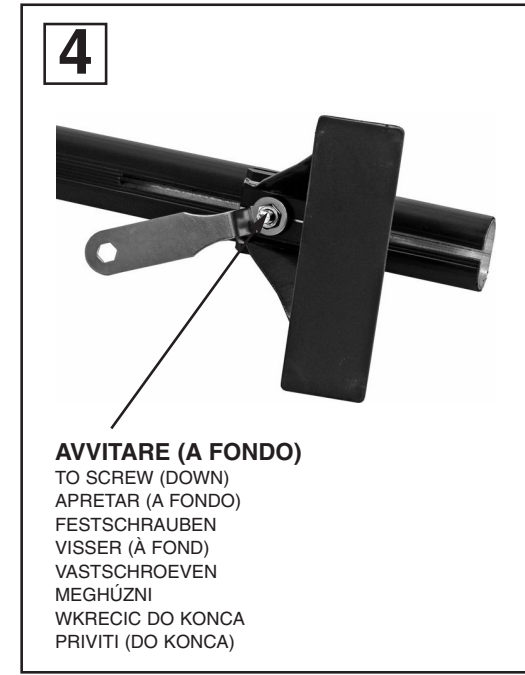

7

MODELLI AUTO
 CARS
 COCHES
 WAGEN
 VOITURES
 AUTO
 AUTÓ TIPUS
 MODELI AVTOMOBILOV

		ANTERIORE FRONT DELANTERO VORDERE AVANT VOORSTE G. ELSŐ RÚD PRZOD SPREDAJ	POSTERIORE REAR TRASERO HINTERE ARRIERE ACHTERSTE G. HÁTSÓ RÚD TYL ZADAJ
		N°	N°
ALFA ROMEO 147 3P		54	54P

MONTAGGIO GANASCINE
 HOW TO ASSEMBLE THE CLAMPS
 COMO MONTAR LAS FIJACIONES
 ZUSAMMENBAU DER
 SPANNBACKEN
 MONTAGE CROCHET
 MONTAGE VAN DE KLEMMEN
 RÖGZÍTŐ FÜLEK
 MONTAZ SZCZEK MOCUJACYCH
 MONTÁZA NAPENJALNIKA

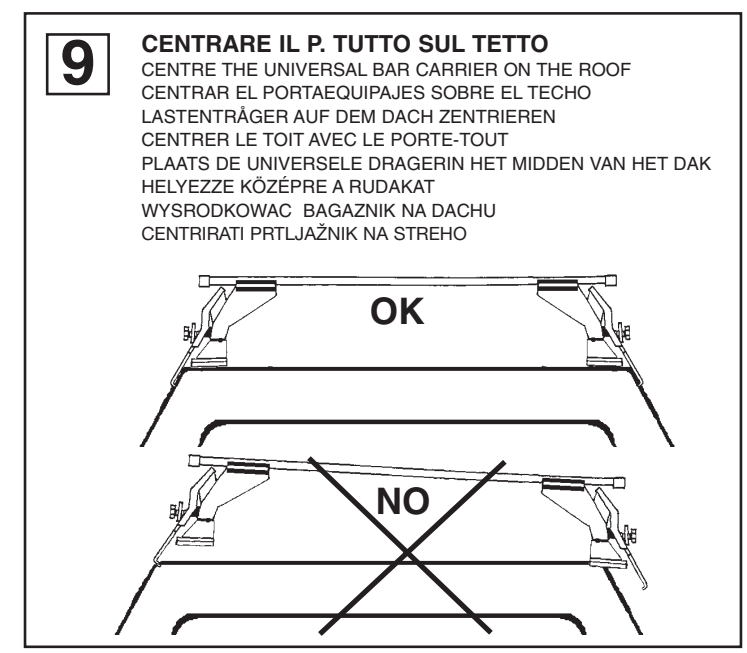
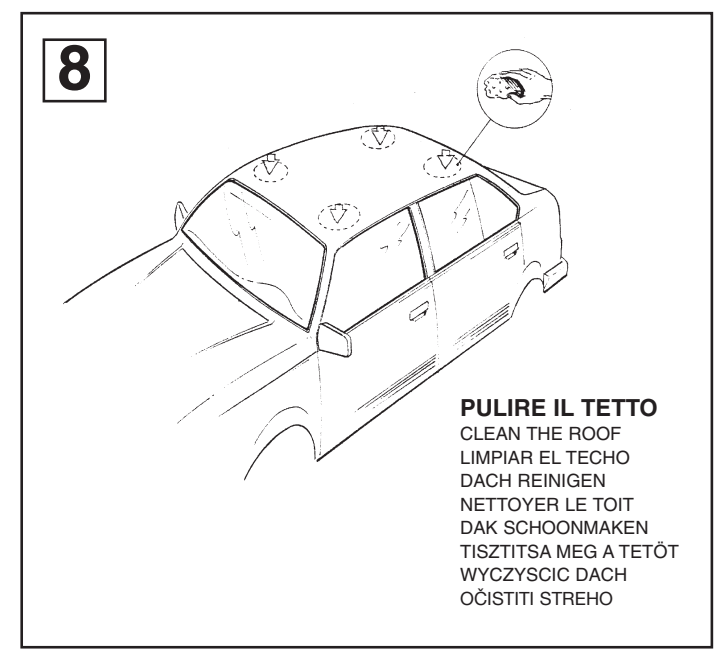

MODELLI CON PREDISPOSIZIONE DELLA CASA AUTO:

CARS WITH PRE-EXISTING FIXING POINT FROM MANUFACTURER
 MODELOS CON PREDISPOSICION DEL FABRICANTE
 AUTOS MIT VOM HERSTELLER VORGESEHENE BEFESTIGUNGSPUNKTE
 VOITURES AVEC POINTS DE FIXAGE PREVUS PAR LE CONSTRUCTEUR
 AUTO'S MET DOOR DE FABRIKANT VOORZIENE MONTAGEPUNTEN
 FELHELYEZÉS GYÁRTÓ ÁLTAL KIJELÖLT PONTRA
 SAMOCHODY Z PRZEWDZIANYMI PUNKTAMI UMOCOWANIA
 MODELI Z PREDVIDENIM LEŽIŠČEM S STRANI PROIZVAJALCA

MODELLI AUTO

CARS
 COCHES
 WAGEN
 VOITURES
 AUTO
 AUTÓ TIPUS
 MODELI AVTOMOBILOV

ANTERIORE

FRONT
 DELANTERO
 VORDERE
 AVANT
 VOORSTE G.
 ELSŐ RÚD
 PRZOD
 SPREDAJ

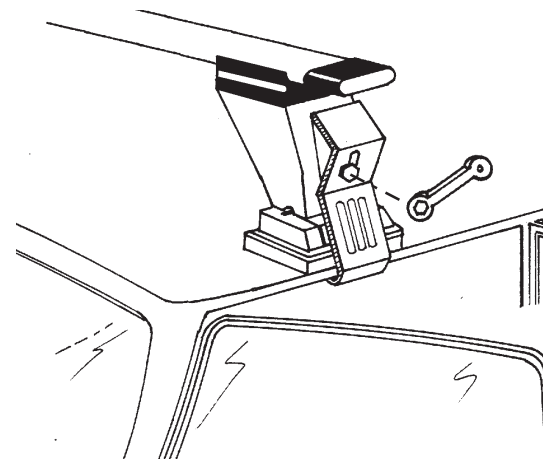
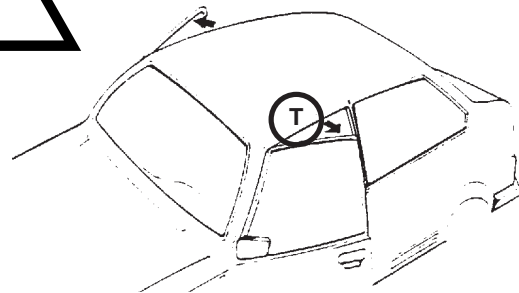
ALFA ROMEO 147 3P**T****10****AVVITARE**

TO SCREW
 APRETAR
 FESTSCHRAUBEN
 VISSER
 VASTSCHROEVEN
 MEGHÚZNI
 WKRECIC
 PRIVITI

MODELLI AUTO

CARS
 COCHES
 WAGEN
 VOITURES
 AUTO
 AUTÓ TIPUS
 MODELI AVTOMOBILOV

POSTERIORE

REAR
 TRASERO
 HINTERE
 ARRIERE
 ACHTERSTE G.
 HÁTSÓ RÚD
 TYL
 ZADAJ

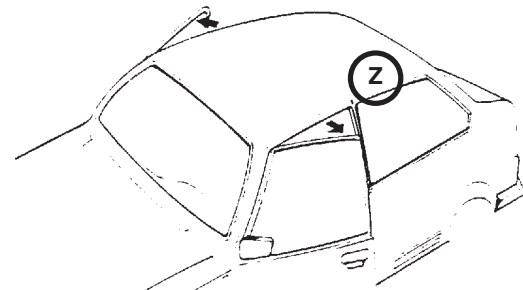
ALFA ROMEO 147 3P**Z****VETRO FISSO**

NON OPENING WINDOW
 CRISTAL FIJO
 FESTE GLASSCHEIBE
 GLACE FIXE
 VASTE RUIT
 FIX ÜVEGEZÉS
 SZYBA STALA
 OKNO BREZ MOŽNOSTI ODPIRANJA

VETRO APRIBILE

OPENING WINDOW
 CRISTAL ABATIBLE
 ZU ÖFFNENDE GLASSCHEIBE
 GLACE OUVRABLE
 TE OPENEN RUIT
 NYITHATÓ ÜVEGEZÉS
 SZYBA OTWIERAJACA SIE
 OKNO Z MOŽNOSTJO ODPIRANJA

AVVITARE

TO SCREW
 APRETAR
 FESTSCHRAUBEN
 VISSER
 VASTSCHROEVEN
 MEGHÚZNI
 WKRECIC
 PRIVITI

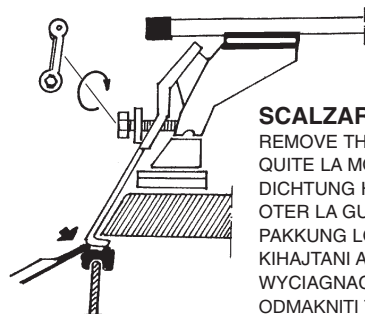
**SCALZARE LA GUARNIZIONE**

REMOVE THE GASKET
 QUITE LA MOLDURA
 DICHTUNG HERAUSZIEHEN
 OTER LA GUARNITURE
 PAKKUNG LOSMAKEN
 KIHAJTANI A TÖMITÖGUMIT
 WYCIAGNAC USZCZELKE
 ODMAKNITI TESNILO

AVVITARE

TO SCREW
 APRETAR
 FESTSCHRAUBEN
 VISSER
 VASTSCHROEVEN
 MEGHÚZNI
 WKRECIC
 PRIVITI

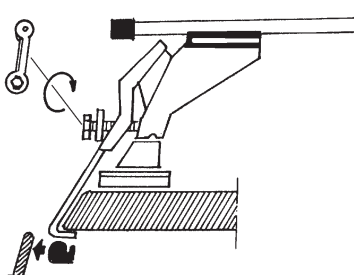
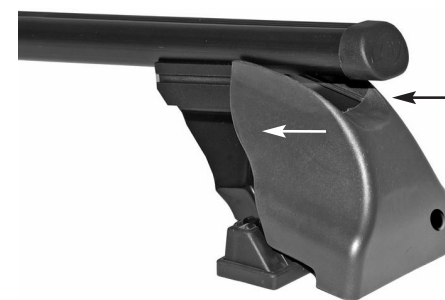
**11****INSERIRE**

INSERT
 CUBRIR
 STOPFEN
 ENFILER
 BEVESTIG
 TOLJA FEL
 NALOZIC
 VSTAVITI.

12**INSERIRE**

INSERT
 CUBRIR
 STOPFEN
 ENFILER
 BEVESTIG
 TOLJA FEL
 NALOZIC
 VSTAVITI.