

**Attenzione:** Istruzioni di montaggio per barre in ferro.  
**Attention:** Notices de montage pour barres de portage en fer.  
**Attention:** Mounting instructions for bar-carriers made of iron.  
**Atencion:** Instrucciones de montaje para barras portatodo en hierro.  
**Achtung:** Montageanweisungen fuer lastentraeger aus eisen.  
**Attentie:** Handleiding voor dakdragers gemaakt van ijzer.  
**Uwaga:** Instrukcja montażu bagażników wykonanych ze stali.  
**Pozor:** Navodila za montažo nosilcev prtljažnika - železnih.  
 Szerelési utasítás acél tartórudakhoz.

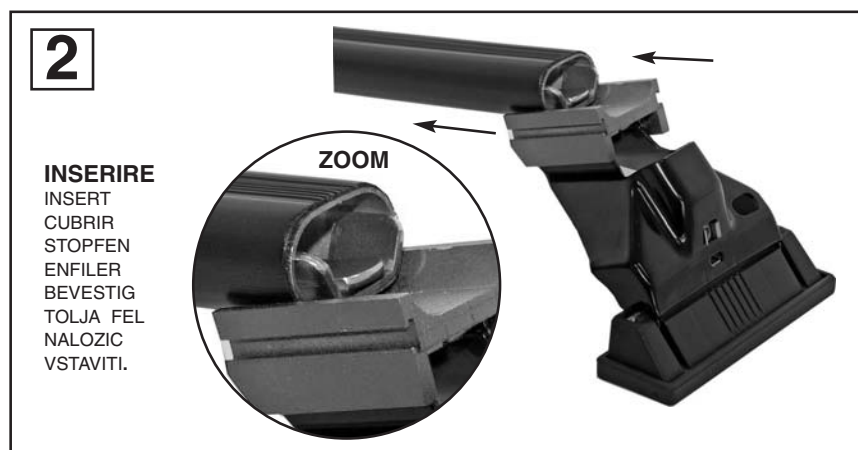
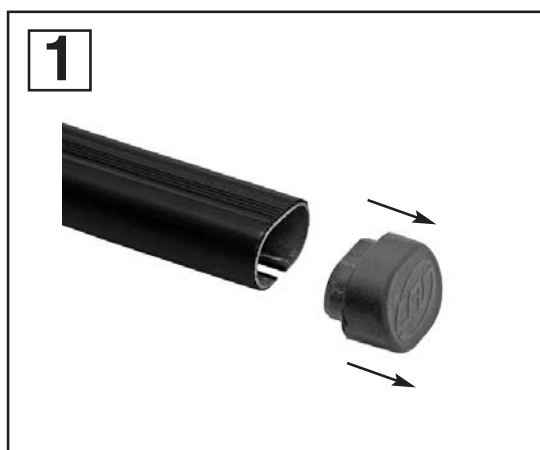

**3**

 <b>MODELLI AUTO / CARS / COCHES / WAGEN / VOITURES / AUTO / AUTÓ TIPUS / MODELI AVTOMOBILOV.</b> NISSAN MICRA 5P (03->)	 <b>ANTERIORE</b> FRONT DELANTERO VORDERE	AVANT VOORSTE G. ELSŐ RÜD PRZOD SPREDAJ	 <b>POSTERIORE</b> REAR TRASERO HINTERE	ARRIERE ACHTERSTE G. HÁTÓS RÜD TYL ZADAJ
	68 mm.	89 mm.		

**MISURE PRECISE**  
 EXACT DIMENSIONS  
 MEDIDAS CORRECTAS  
 GENAUE MASSE  
 MESURES EXACTES  
 EXACTE AFMETINGEN  
 PONTOS MÉRET  
 DOKŁADNE WYMIARY  
 TO» NE MERE

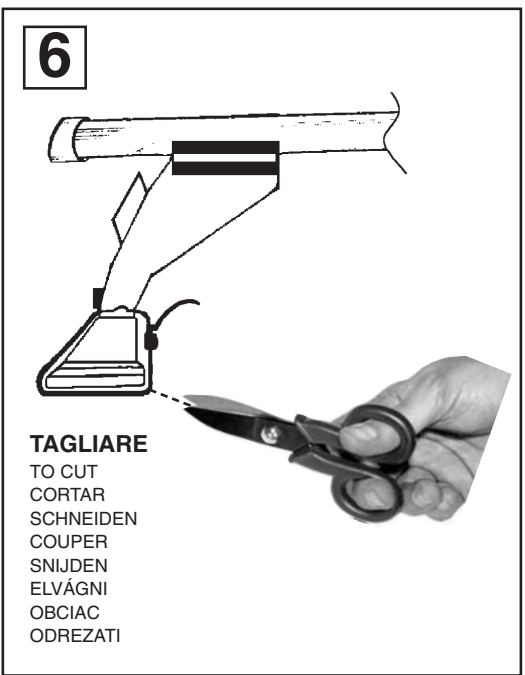

**7**

**MODELLI AUTO**  
 CARS  
 COCHES  
 WAGEN  
 VOITURES  
 AUTO  
 AUTÓ TIPUS  
 MODELI AVTOMOBILOV

		<b>ANTERIORE</b> FRONT DELANTERO VORDERE AVANT VOORSTE G. ELŐ RÜD PRZOD SPREDAJ	<b>POSTERIORE</b> REAR TRASERO HINTERE ARRIERE ACHTERSTE G. HÁTÓS RÜD TYL ZADAJ
		N°	N°
NISSAN MICRA 5P (03->)		5	57P

**MONTAGGIO GANASCINE**  
 HOW TO ASSEMBLE THE CLAMPS  
 COMO MONTAR LAS FIJACIONES  
 ZUSAMMENBAU DER SPANNBACKEN  
 MONTAGE CROCHET  
 MONTAGE VAN DE KLEMMEN  
 RÖGZÍTŐ FÜLEK  
 MONTAZ SZCZEK MOCUJACYCH  
 MONTAŽA NÁPENJALNIKA

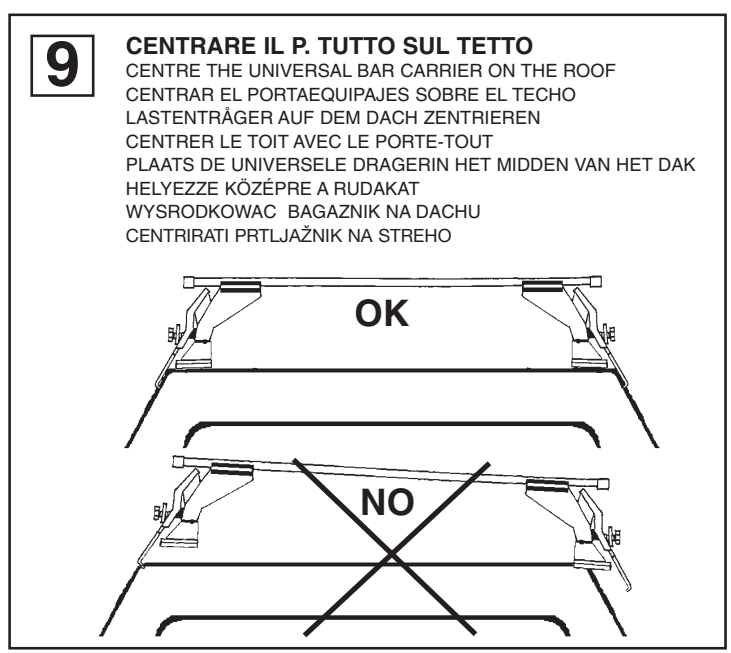
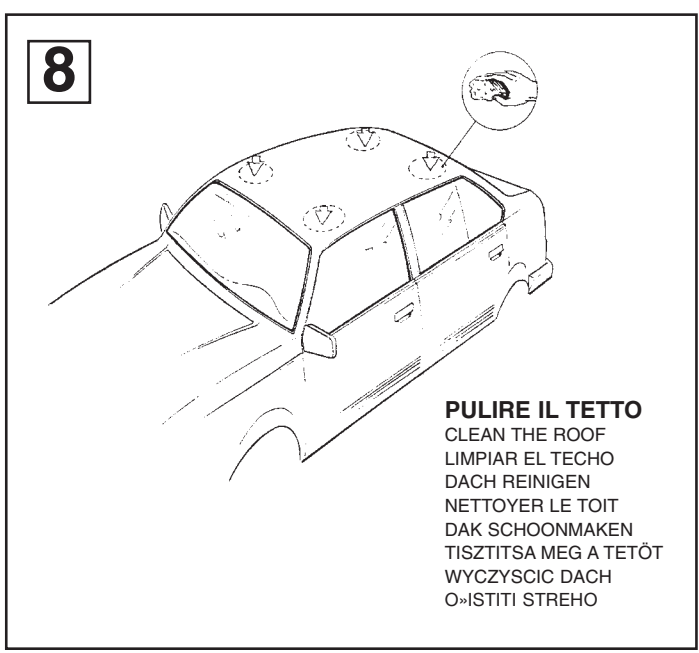

**MODELLI SENZA PREDISPOSIZIONE DELLA CASA AUTO:**

CARS WITHOUT PRE-EXISTING FIXING POINT  
 PARA COCHES SIN PREDISPOSICION DEL FABRICANTE  
 AUTOS OHNE VOM HERSTELLER VORGESEHENE BEFESTIGUNGSPUNKTE  
 VOITURES SANS POINTS DE FIXAGE PRÉVUS PAR LE CONSTRUCTEUR  
 AUTO'S ZONDER DOOR DE FABRIKANT VOORZIENE BEVESTIGINGSPUNTEN  
 FELHELYEZES GYÁRI JELÖLÉS NÉLKÜLI AUTÓKRA  
 SAMOCHODY BEZ PRZEWIDZIANYCH PUNKTOW UMOCOWANIA  
 MODELI Z NEPREDVIDENIM LEŽIŠ-EM S STRANI PROIZVAJALCA

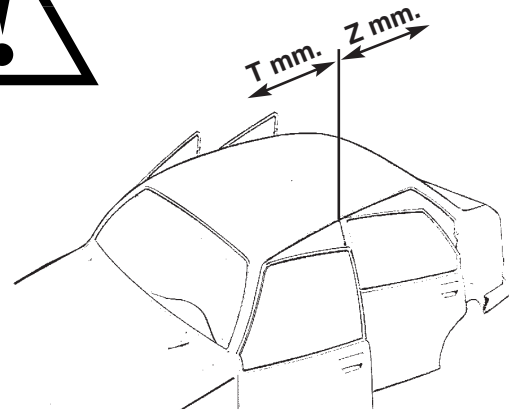
**10****MODELLI AUTO**

CARS  
 COCHES  
 WAGEN  
 VOITURES  
 AUTO  
 AUTÓ TIPUS  
 MODELI AVTOMOBILOV

ANTERIORE	POSTERIORE
FRONT	REAR
DELANTERO	TRASERO
VORDERE	HINTERE
AVANT	ARRIERE
VOORSTE G.	ACHTERSTE G.
ELSO RÜD	HÄTSÖ RÜD
PRZOD	TYL
SPREDAJ	ZADAJ

**T****Z**

NISSAN MICRA 5P ( 03 ->)	310 mm.	300 mm.
--------------------------	---------	---------

**AVVITARE**

TO SCREW  
 APRETAR  
 FESTSCHRAUBEN  
 VISSER  
 VASTSCHROEVEN  
 MEGHÚZNI  
 WKRECIC  
 PRIVITI

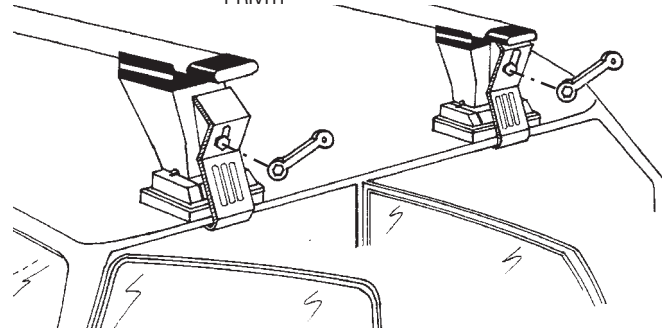
**11****INSERIRE**

INSERT  
 CUBRIR  
 STOPFEN  
 ENFILER  
 BEVESTIG  
 TOLJA FEL  
 NALOZIC  
 VSTAVITI.

**12****INSERIRE**

INSERT  
 CUBRIR  
 STOPFEN  
 ENFILER  
 BEVESTIG  
 TOLJA FEL  
 NALOZIC  
 VSTAVITI.