

Attenzione: Istruzioni di montaggio per barre in ferro.
Attention: Notices de montage pour barres de portage en fer.
Attention: Mounting instructions for bar-carriers made of iron.
Atencion: Instrucciones de montaje para barras portatodo en hierro.
Achtung: Montageanweisungen fuer lastentraeger aus eisen.
Attentie: Handleiding voor dakdragers gemaakt van ijzer.
Uwaga: Instrukcja montażu bagażników wykonanych ze stali.
Pozor: Navodila za montažo nosilcev prtljažnika - železnih.
 Szerelési utasítás acél tartórudakhoz.

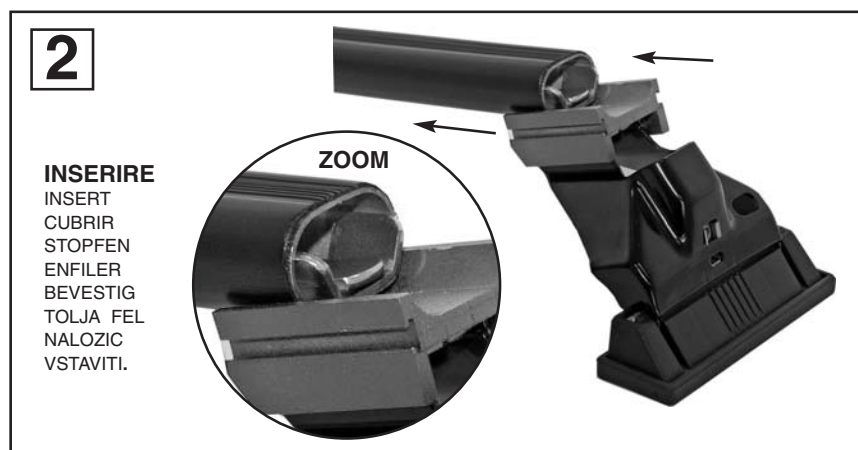
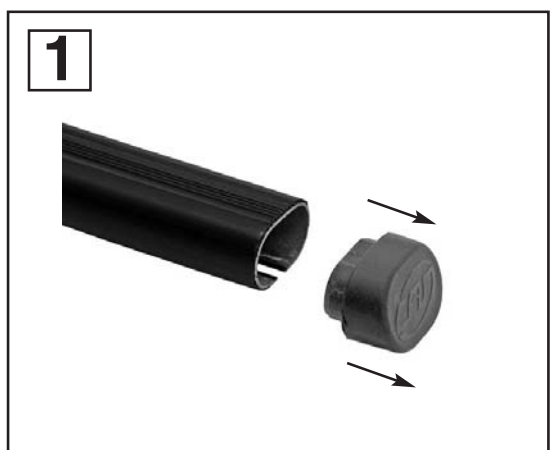

3

 MODELLI AUTO / CARS / COCHES / WAGEN / VOITURES / AUTO / AUTÓ TIPUS / MODELI AVTOMOBILOV.	 ANTERIORE FRONT DELANTERO VORDERE	AVANT VOORSTE G. ELSŐ RÜD PRZOD SPREDAJ	 POSTERIORE REAR TRASERO HINTERE	ARRIERE ACHTERSTE G. HÁTSÓ RÜD TYL ZADAJ
	CITROEN C3 TOYOTA YARIS 5P (->05)	46 mm. 61 mm.		55 mm. 76 mm.

ZOOM

MISURE PRECISE
 EXACT DIMENSIONS
 MEDIDAS CORRECTAS
 GENAUE MASSE
 MESURES EXACTES
 EXACTE AFMETINGEN
 PONTOS MÉRET
 DOKŁADNE WYMIARY
 TO» NE MERE

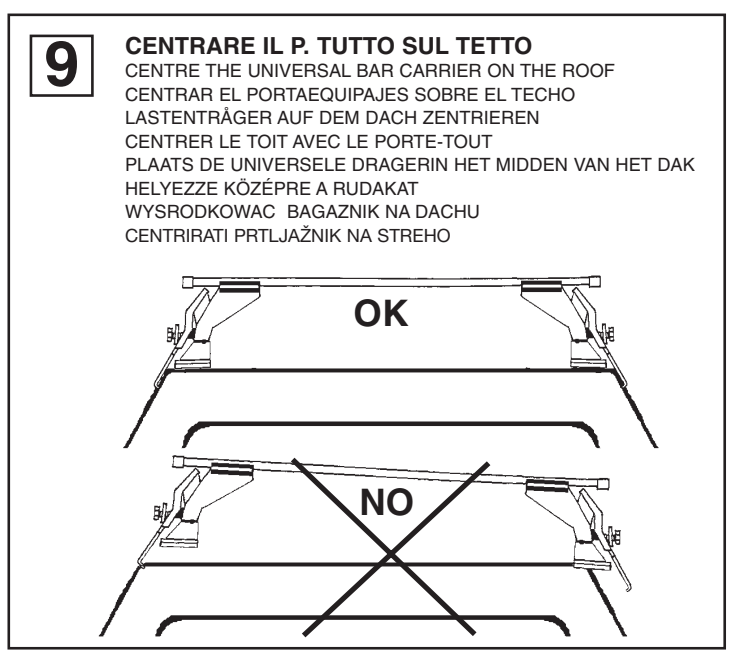
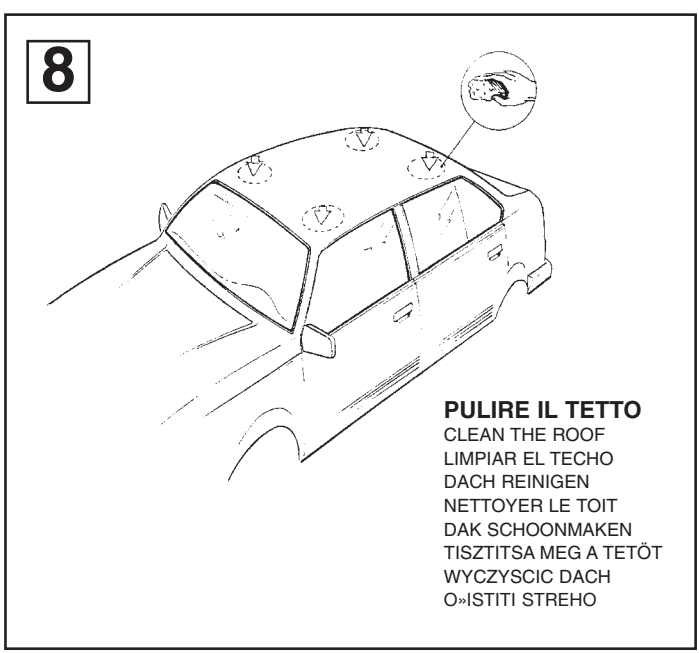
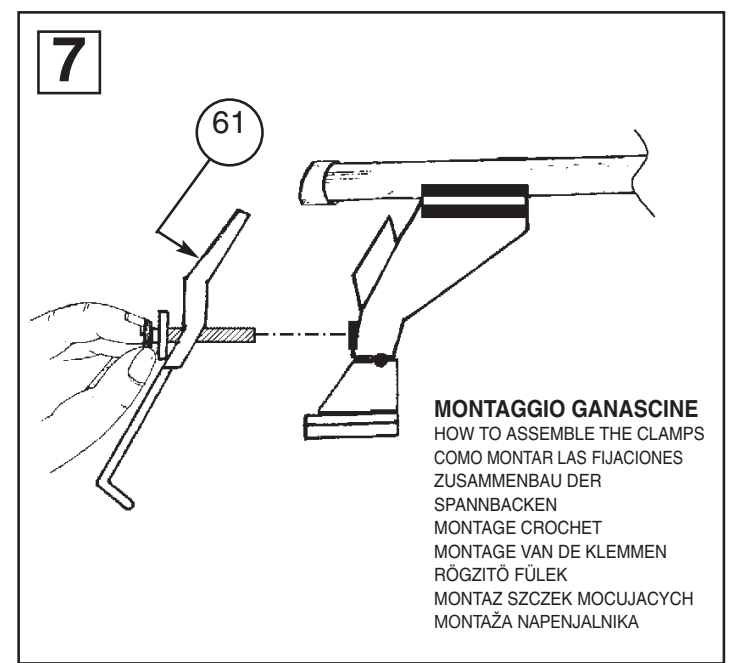
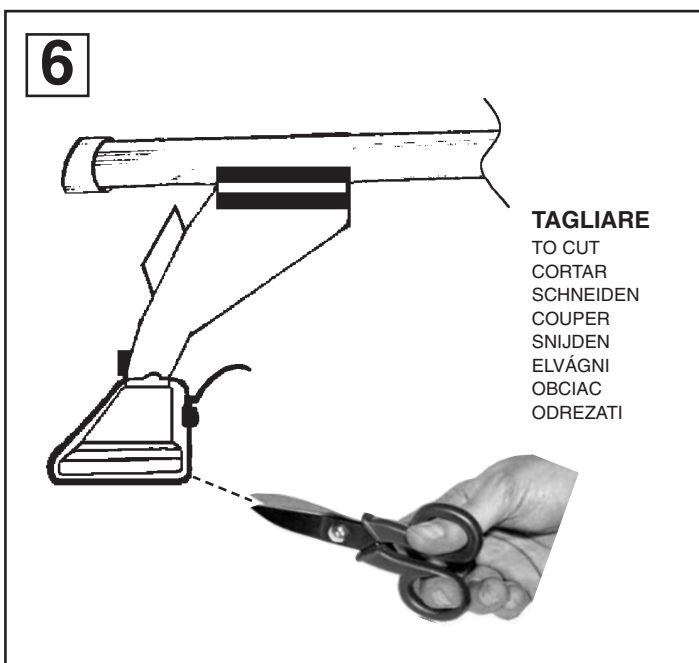
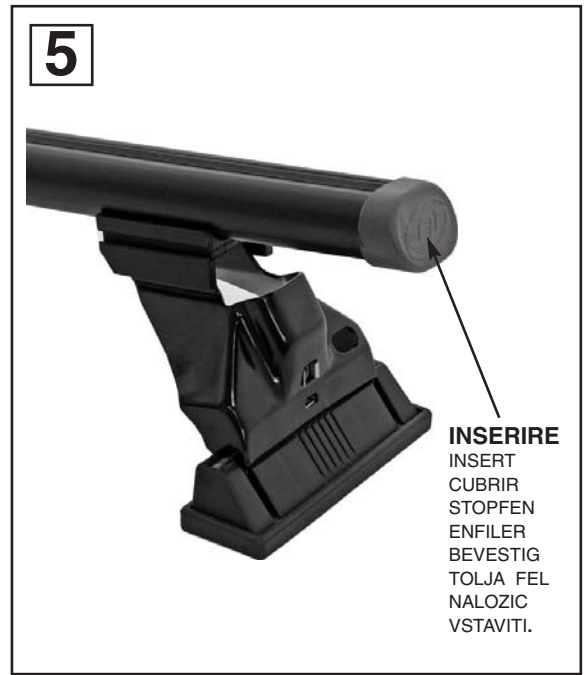
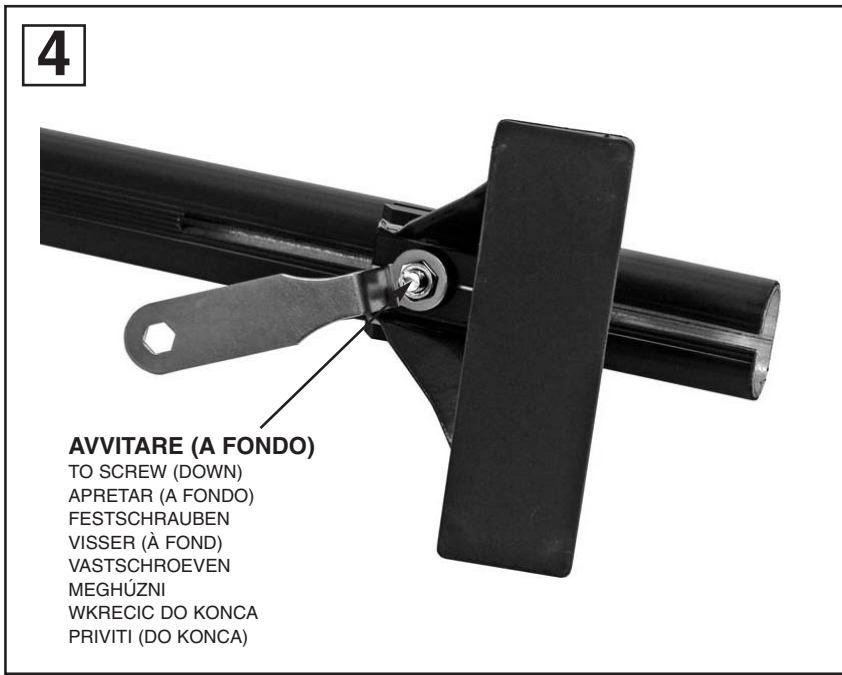

MODELLI SENZA PREDISPOSIZIONE DELLA CASA AUTO:

CARS WITHOUT PRE-EXISTING FIXING POINT
 PARA COCHES SIN PREDISPOSICION DEL FABRICANTE
 AUTOS OHNE VOM HERSTELLER VORGESEHENE BEFESTIGUNGSPUNKTE
 VOITURES SANS POINTS DE FIXAGE PRÉVUS PAR LE CONSTRUCTEUR
 AUTO'S ZONDER DOOR DE FABRIKANT VOORZIENE BEVESTIGINGSPUNTEN
 FELHELYEZES GYÁRI JELÖLÉS NÉLKÜLI AUTÓKRA
 SAMOCHODY BEZ PRZEWIDZIANYCH PUNKTOW UMOCOWANIA
 MODELI Z NEPREDVIDENIM LEŽIŠ»EM S STRANI PROIZVAJALCA

10**MODELLI AUTO**

CARS
 COCHES
 WAGEN
 VOITURES
 AUTO
 AUTÓ TIPUS
 MODELI AVTOMOBILOV

ANTERIORE
 FRONT
 DELANTERO
 VORDERE
 AVANT
 VOORSTE G.
 ELSŐ RÜD
 PRZOD
 SPREDAJ

POSTERIORE
 REAR
 TRASERO
 HINTERE
 ARRIERE
 ACHTERSTE G.
 HÁTSÓ RÜD
 TYL
 ZADAJ

T**Z**

CITROEN C3	250 mm.	350 mm.
TOYOTA YARIS 5P (->05)	200 mm.	500 mm.

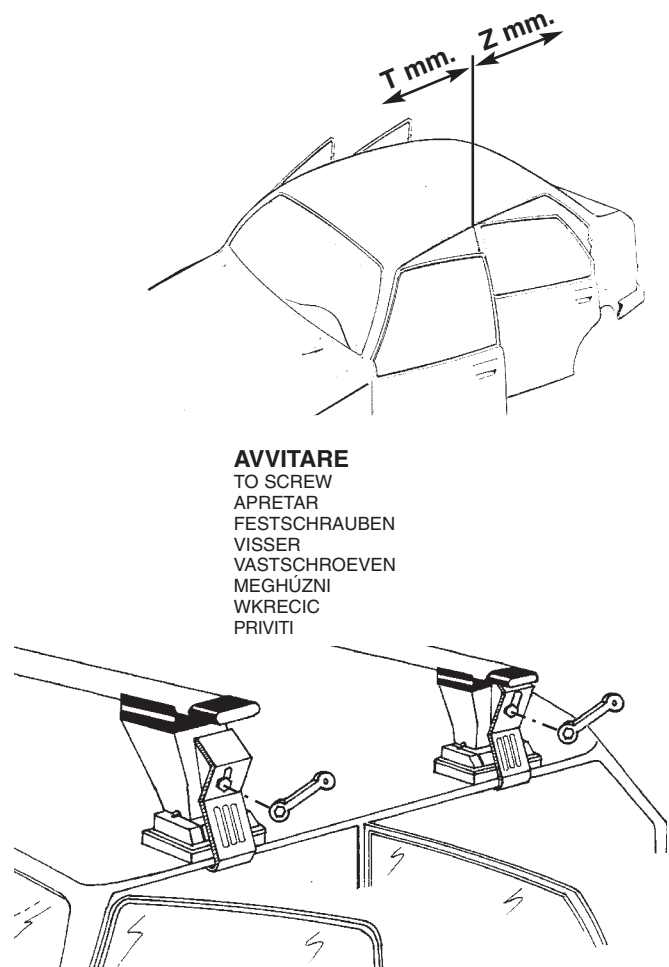
**11**

INSERIRE
 INSERT
 CUBRIR
 STOPFEN
 ENFILER
 BEVESTIG
 TOLJA FEL
 NALOZIC
 VSTAVITI.

12

INSERIRE
 INSERT
 CUBRIR
 STOPFEN
 ENFILER
 BEVESTIG
 TOLJA FEL
 NALOZIC
 VSTAVITI.