

Attenzione: Istruzioni di montaggio per barre in ferro.
Attention: Notices de montage pour barres de portage en fer.
Attention: Mounting instructions for bar-carriers made of iron.
Atencion: Instrucciones de montaje para barras portatodo en hierro.
Achtung: Montageanweisungen fuer lastentraeger aus eisen.
Attentie: Handleiding voor dakdragers gemaakt van ijzer.
Uwaga: Instrukcja montażu bagażników wykonanych ze stali.
Pozor: Navodila za montažo nosilcev prtljažnika - železnih.
 Szerelési utasítás acél tartórudakhoz.

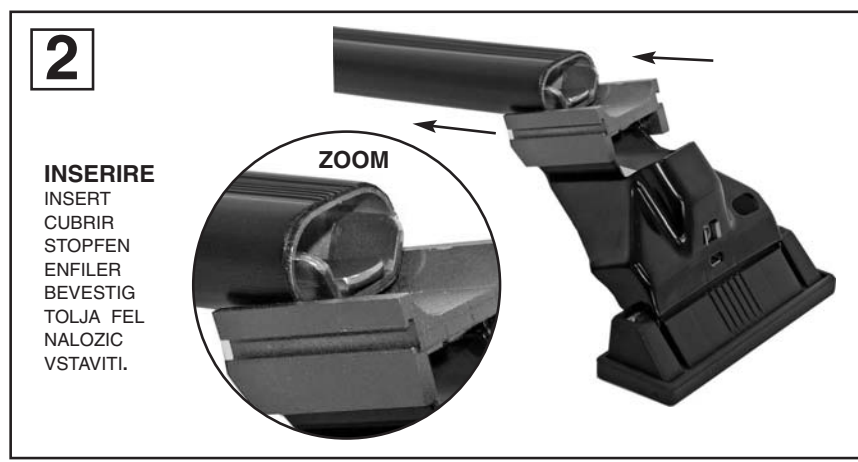
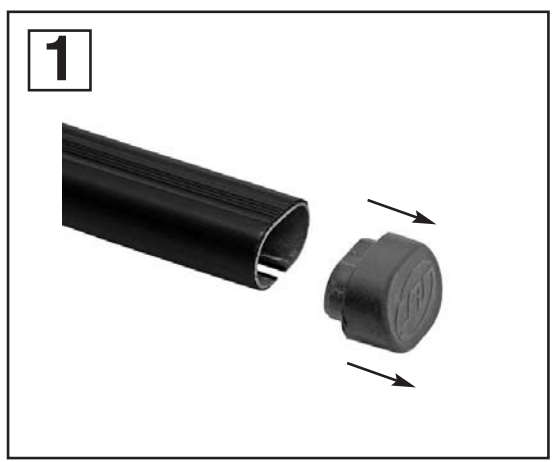

3

MODELLI AUTO / CARS / COCHES / WAGEN / VOITURES / AUTO / AUTÓ TIPUS / MODELÍ AVTOMOBILOV.	ANTERIORE FRONT DELANTERO VORDERE	AVANT VOORSTE G. ELSO RÜD PRZOD SPREDAJ	POSTERIORE REAR TRASERO HINTERE	ARRIERE ACHTERSTE G. HÄTÖ RÜD TYL ZADAJ
FORD NUOVA FIESTA 5P (02->)	120 mm.		142 mm.	
FORD FUSION	109 mm.		137 mm.	

MISURE PRECISE
 EXACT DIMENSIONS
 MEDIDAS CORRECTAS
 GENAUE MASSE
 MESURES EXACTES
 EXACTE AFMETINGEN
 PONTOS MÉRET
 DOKŁADNE WYMIARY
 TO» NE MERE

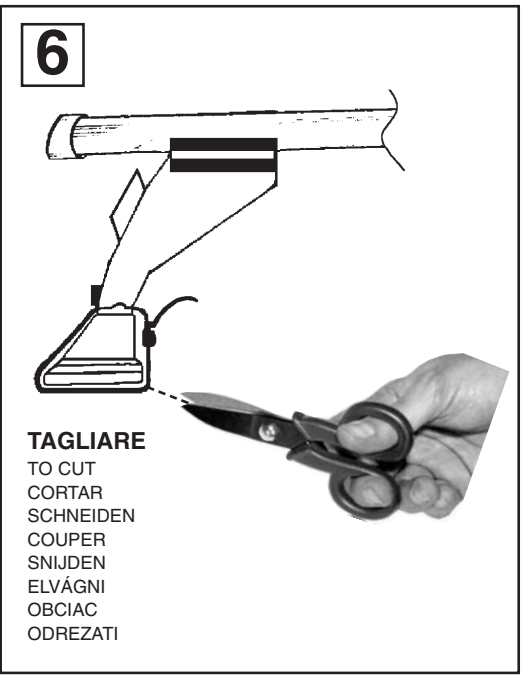

7

MODELLI AUTO
 CARS
 COCHES
 WAGEN
 VOITURES
 AUTO
 AUTÓ TIPUS
 MODELÍ AVTOMOBILOV

	5	43
ANTERIORE FRONT DELANTERO VORDERE AVANT VOORSTE G. ELSO RÜD PRZOD SPREDAJ	N°	N°
POSTERIORE REAR TRASERO HINTERE ARRIERE ACHTERSTE G. HÄTÖ RÜD TYL ZADAJ	N°	N°

FORD NUOVA FIESTA 5P (02->) 5 43
 FORD FUSION 5 43

MONTAGGIO GANASCINE
 HOW TO ASSEMBLE THE CLAMPS
 COMO MONTAR LAS FIJACIONES
 ZUSAMMENBAU DER SPANNBACKEN
 MONTAGE CROCHET
 MONTAGE VAN DE KLEMMEN
 RÖGZITŐ FÜLEK
 MONTAZ SZCZEK MOCUJACYCH
 MONTÁŽA NAPENJALNIKA

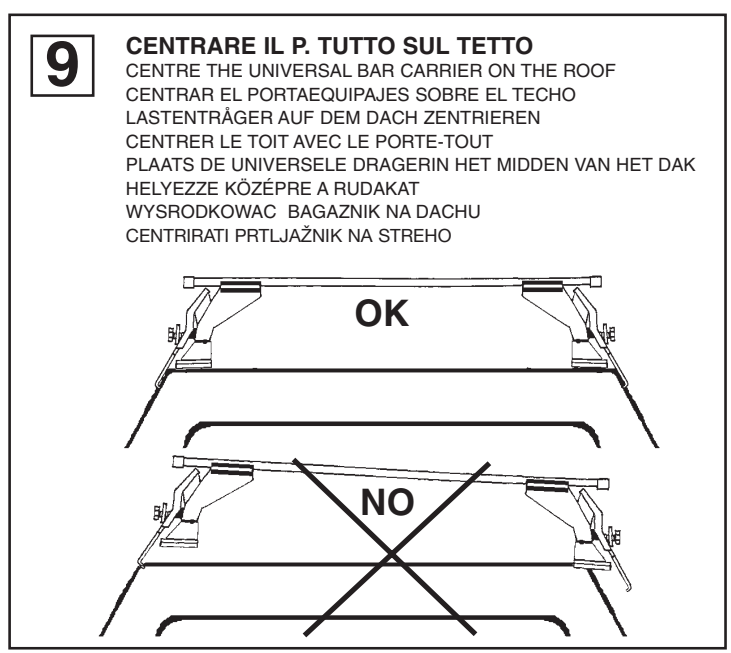
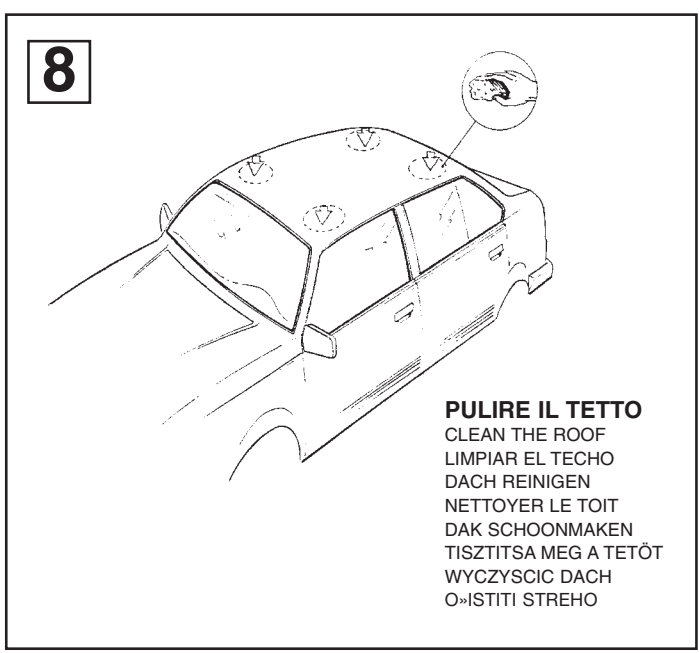

MODELLI SENZA PREDISPOSIZIONE DELLA CASA AUTO:

CARS WITHOUT PRE-EXISTING FIXING POINT
 PARA COCHES SIN PREDISPOSICION DEL FABRICANTE
 AUTOS OHNE VOM HERSTELLER VORGESEHENE BEFESTIGUNGSPUNKTE
 VOITURES SANS POINTS DE FIXAGE PRÉVUS PAR LE CONSTRUCTEUR
 AUTO'S ZONDER DOOR DE FABRIKANT VOORZIENE BEVESTIGINGSPUNTEN
 FELHELYEZES GYÁRI JELÖLÉS NÉLKÜLI AUTÓKRA
 SAMOCHODY BEZ PRZEWIDZIANYCH PUNKTOW UMOCOWANIA
 MODELI Z NEPREDVIDENIM LEŽIŠ-EM S STRANI PROIZVAJALCA

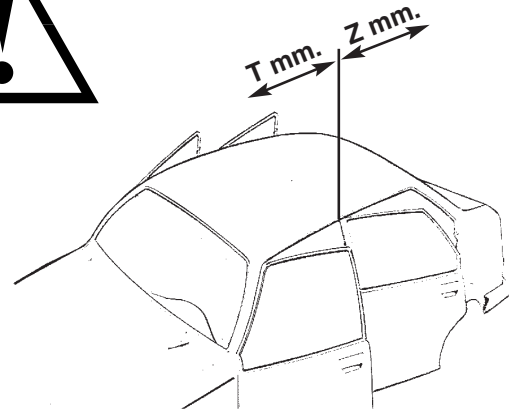
**10****MODELLI AUTO**

CARS
 COCHES
 WAGEN
 VOITURES
 AUTO
 AUTÓ TIPUS
 MODELI AVTOMOBILOV

ANTERIORE	POSTERIORE
FRONT	REAR
DELANTERO	TRASERO
VORDERE	HINTERE
AVANT	ARRIERE
VOORSTE G.	ACHTERSTE G.
ELŐ RÜD	HÁTÓ RÜD
PRZOD	TYL
SPREDAJ	ZADAJ

T**Z**

FORD NUOVA FIESTA 5P (02->)	250 mm.	450 mm.
FORD FUSION	250 mm.	450 mm.

AVVITARE

TO SCREW
 APRETAR
 FESTSCHRAUBEN
 VISSER
 VASTSCHROEVEN
 MEGHÚZNI
 WKRECIC
 PRIVITI

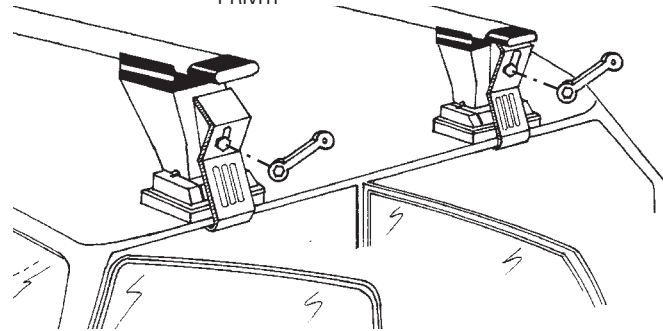
**11****INSERIRE**

INSERT
 CUBRIR
 STOPFEN
 ENFILER
 BEVESTIG
 TOLJA FEL
 NALOZIC
 VSTAVITI.

12**INSERIRE**

INSERT
 CUBRIR
 STOPFEN
 ENFILER
 BEVESTIG
 TOLJA FEL
 NALOZIC
 VSTAVITI.