

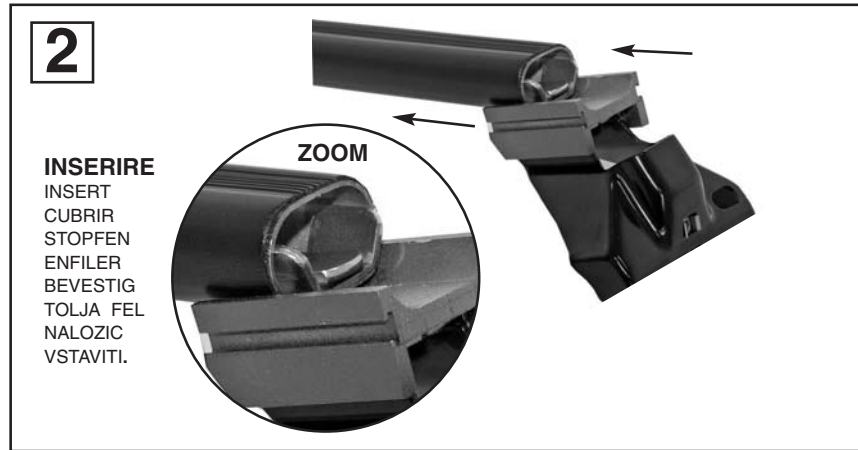



**Attenzione:** Istruzioni di montaggio per barre in ferro.  
**Attention:** Notices de montage pour barres de portage en fer.  
**Attention:** Mounting instructions for bar-carriers made of iron.  
**Atencion:** Instrucciones de montaje para barras portatodo en hierro.  
**Achtung:** Montageanweisungen fuer lastentraeger aus eisen.  
**Attentie:** Handleiding voor dakdragers gemaakt van ijzer.  
**Uwaga:** Instrukcja montażu bagażników wykonanych ze stali.  
**Pozor:** Navodila za montažo nosilcev prtljažnika - železnih.  
 Szerelési utasítás acél tartórudakhoz.



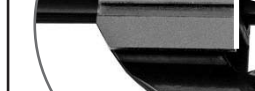

**3**

 <b>MODELLI AUTO / CARS / COCHES / WAGEN / VOITURES / AUTO / AUTÓ TIPUS / MODELI AVTOMOBILOV.</b>	 <b>ANTERIORE</b> FRONT DELANTERO VORDERE	 <b>POSTERIORE</b> REAR TRASERO HINTERE	 <b>ARRIERE</b> ACHTERSTE G. HÁTÓS RÜD TYL ZADAJ
SUZUKI SWIFT 5P (05->)	75 mm.	94 mm.	

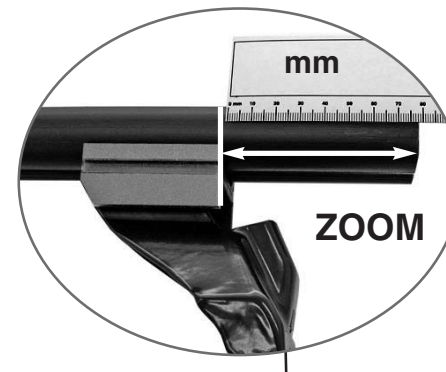



**MISURE PRECISE**  
 EXACT DIMENSIONS  
 MEDIDAS CORRECTAS  
 GENAUE MASSE  
 MESURES EXACTES  
 EXACTE AFMETINGEN  
 PONTOS MÉRET  
 DOKŁADNE WYMIARY  
 TO» NE MERE

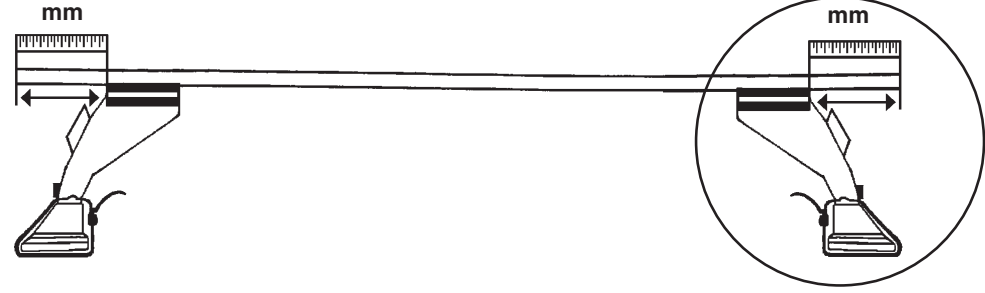

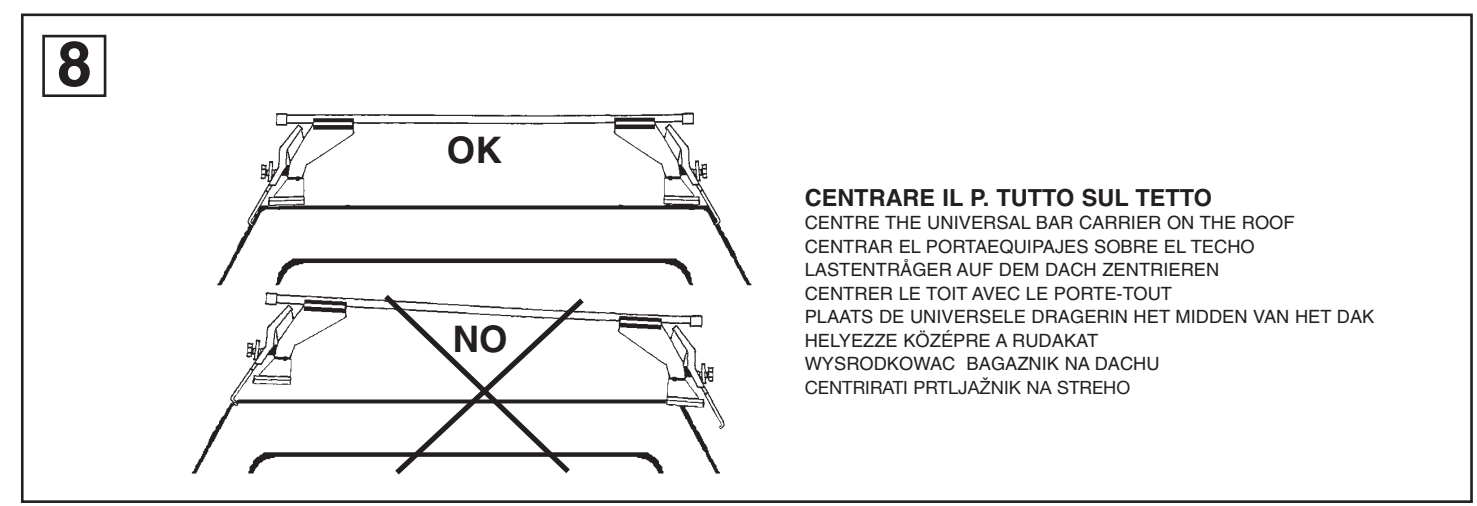
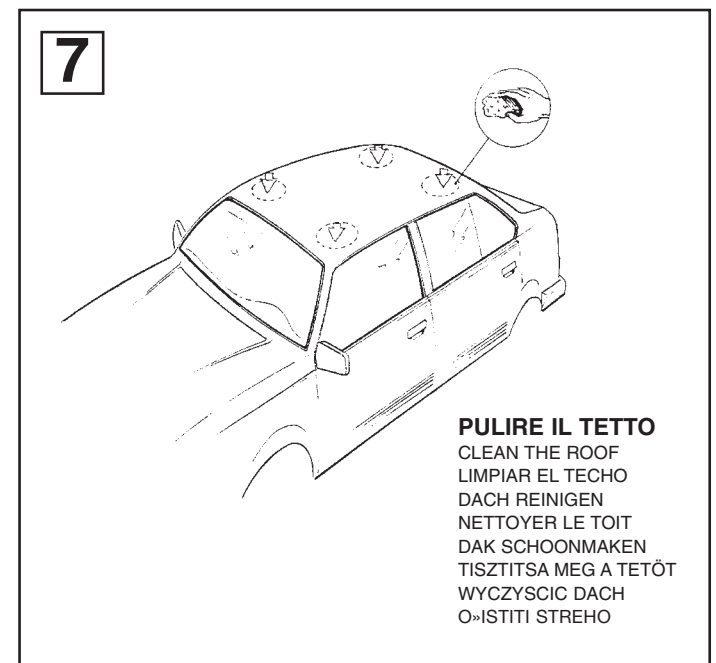
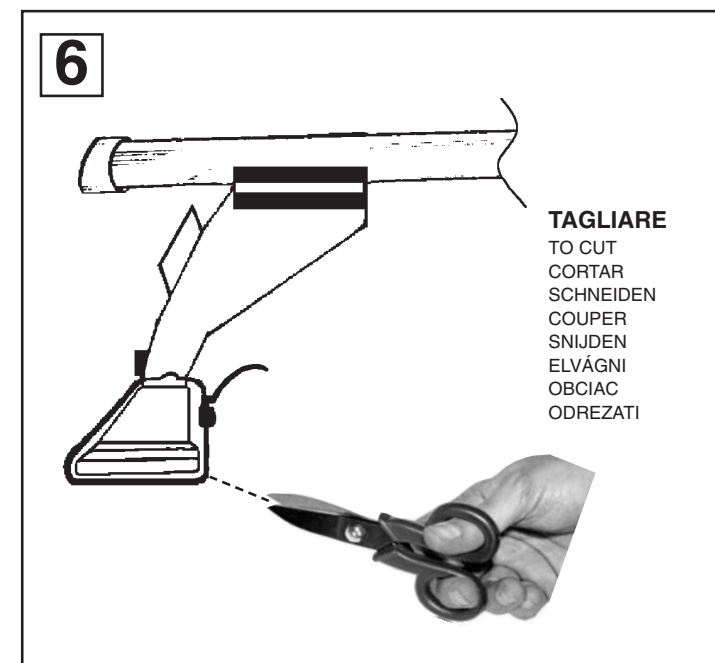
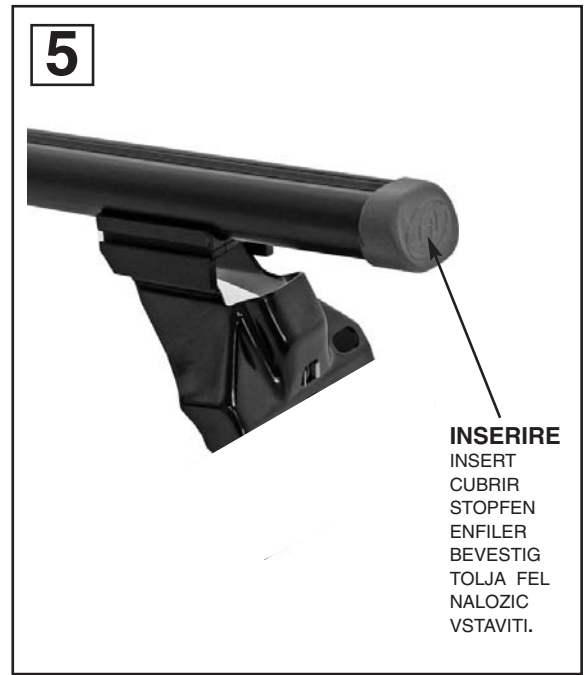
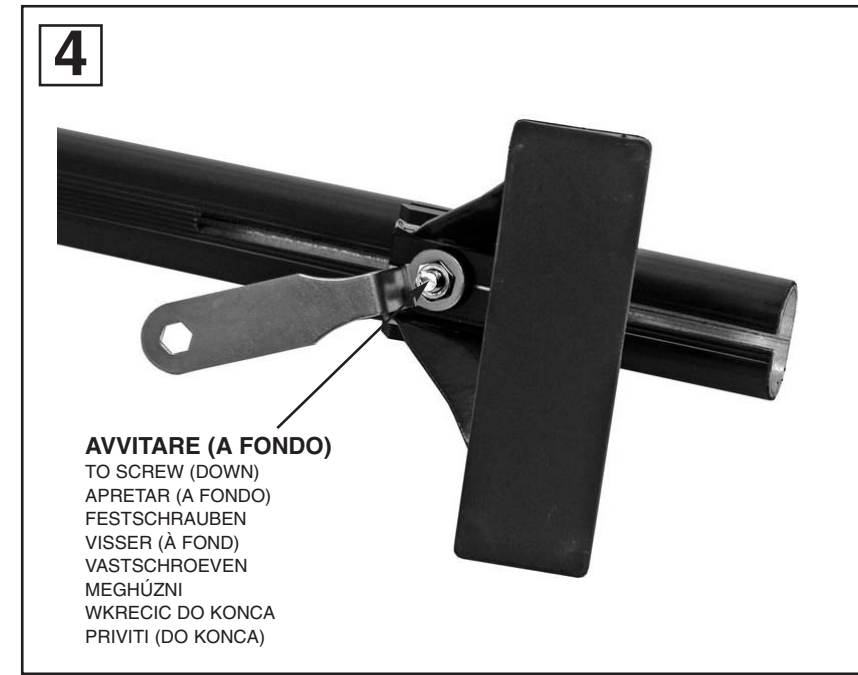

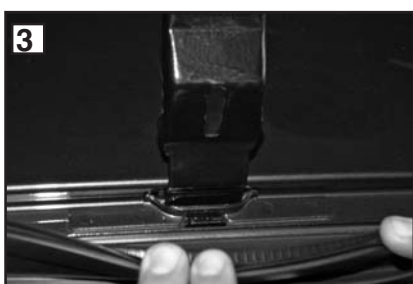

**1**  
**SCALZARE LA GUARNIZIONE**  
 REMOVE THE GASKET  
 QUITE LA MOLDURA  
 DICHTUNG HERAUSZIEHEN  
 OTER LA GUARNITURE  
 PAKKUNG LOSMAKEN  
 KIHAJTANI A TÖMITÖGUMIT  
 WYCIAGNAC USZCZELKE  
 ODMAKNITI TESNILO

**2**  
**INSERIRE**  
 INSERT  
 CUBRIR  
 STOPFEN  
 ENFILER  
 BEVESTIG  
 TOLJA FEL  
 NALOZIC  
 VSTAVITI

**9**

**MODELLI CON PREDISPOSIZIONE DELLA CASA AUTO:**  
 CARS WITH PRE-EXISTING FIXING POINT FROM MANUFACTURER  
 MODELOS CON PREDISPOSICION DEL FABRICANTE  
 AUTOS MIT VOM HERSTELLER VORGESEHENE BEFESTIGUNGSPUNKTE  
 AUTO'S MET DOOR DE FABRIKANT VOORZIENE MONTAGEPUNTEN  
 FELHELYEZÉS GYÁRTÓ ÁLTAL KIJELÖLT PONTRA  
 SAMOCHODY Z PRZEWIDZIANYMI PUNKTAMI UMOCOWANIA  
 MODELI Z PREDVIDENIM LEŽIŠ-EM S STRANI PROIZVAJALCA

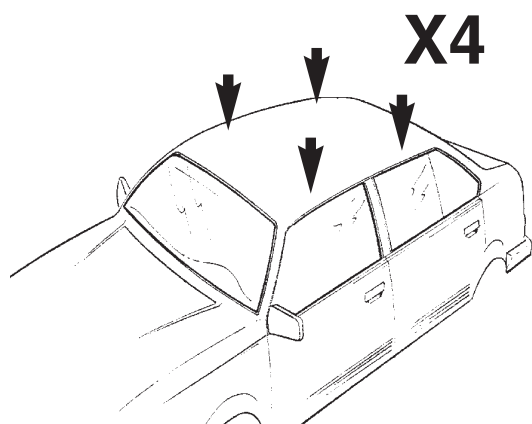

**11**



**INSERIRE**  
 INSERT  
 CUBRIR  
 STOPFEN  
 ENFILER  
 BEVESTIG  
 TOLJA FEL  
 NALOZIC  
 VSTAVITI.

**12**



**INSERIRE**  
 INSERT  
 CUBRIR  
 STOPFEN  
 ENFILER  
 BEVESTIG  
 TOLJA FEL  
 NALOZIC  
 VSTAVITI.

**10**

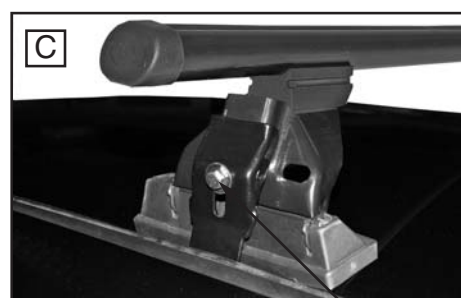
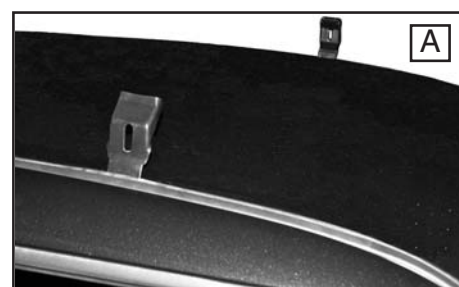

**AVVITARE**  
 TO SCREW  
 APRETAR  
 FESTSCHRAUBEN  
 VISSER  
 VASTSCHROEVEN  
 MEGHÚZNI  
 WKRECIC  
 PRIVITI