



(IT) **Attenzione:** Istruzioni di montaggio per barre in ferro.  
 (GB) **Attention:** Mounting instructions for steel bar carriers.  
 (E) **Atención:** Instrucciones de montaje para barras portatodo en hierro.  
 (D) **Achtung:** Montageanweisungen für Stahl-Lastenträger.  
 (F) **Attention:** Notices de montage pour barres de portage en métal.  
 (NL) **Attentie:** Handleiding voor dakdragers gemaakt van ijzer.  
 (P) **Atenção:** Instruções de montagem para barras de tejadilho em ferro.  
 (H) Szerelési utasítás acél tartórudakhoz.  
 (PL) **Uwaga:** Instrukcja montażu bagażników wykonanych ze stali.  
 (SLO) **Pozor:** Navodila za montažo nosilcev prtljačnika -č eleznih.  
 (HR) Uputstvo za montažu čeljeznih krovnih nosača.



1

**MERCEDES:** Nuova classe A  
 Nuova classe A COUPE'  
 Nuova classe B

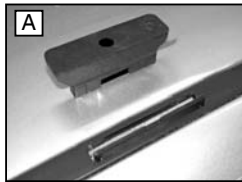

"R TROUVER SUR LE BATTANT DE LA PORTE OU  
 DANS LE MANUAL TECHNIQUE DE LA VOITURE "

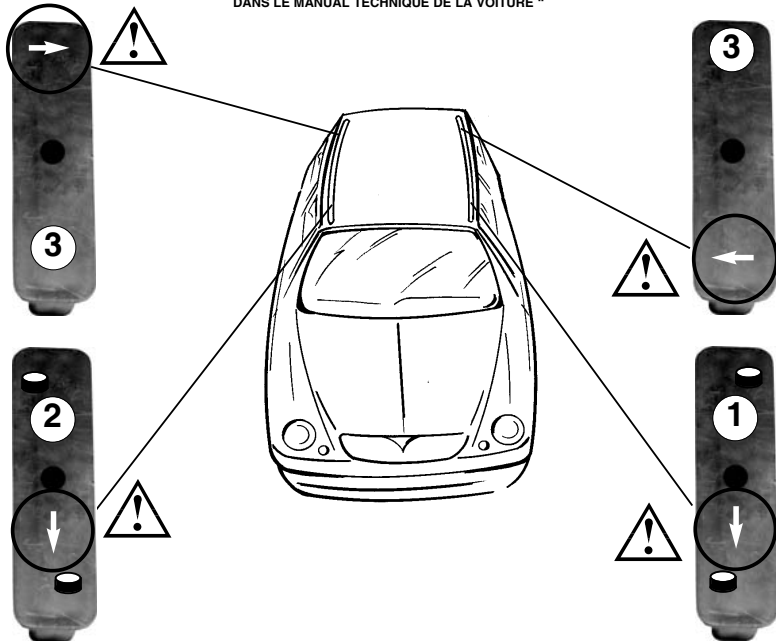

2

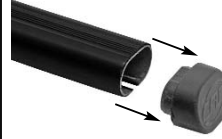

(IT) INSERIRE  
 (GB) INSERT  
 (E) CUBRIR  
 (D) STOPFEN  
 (F) ENFILER  
 (NL) BEVESTIG  
 (P) INSERIR  
 (H) TOLJA FEL  
 (PL) NALOZIC  
 (SLO) VSTAVITI  
 (HR) PREKRITI

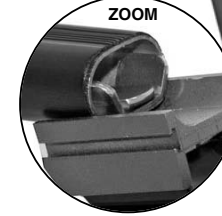

3



(IT) INSERIRE  
 (GB) INSERT  
 (E) CUBRIR  
 (D) STOPFEN  
 (F) ENFILER  
 (NL) BEVESTIG  
 (P) INSERIR  
 (H) TOLJA FEL  
 (PL) NALOZIC  
 (SLO) VSTAVITI  
 (HR) PREKRITI

5

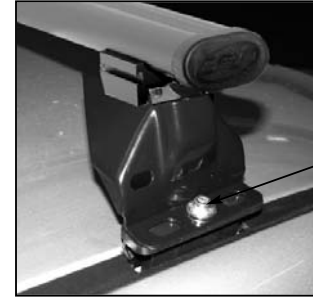

5 Nm

(IT) AVVITARE  
 (GB) TO SCREW  
 (E) APRETAR  
 (D) FESTSCHRAUBEN  
 (F) VISSER  
 (NL) VASTSCHROEVEN  
 (P) APERTAR  
 (H) MEGHÚZNI  
 (PL) WKRECIĆ  
 (SLO) PRIVITI  
 (HR) PRI-VRSTITI

(IT) POSTERIORE  
 (GB) REAR  
 (E) TRASERO  
 (D) HINTERE  
 (F) ARRIERE  
 (NL) ACHTERSTE G.  
 (P) ATRÁS  
 (H) HÁTÓSÓ RÚD  
 (PL) TYŁ  
 (SLO) ZADAJ  
 (HR) STRAČNI



5 Nm

6x35 mm.

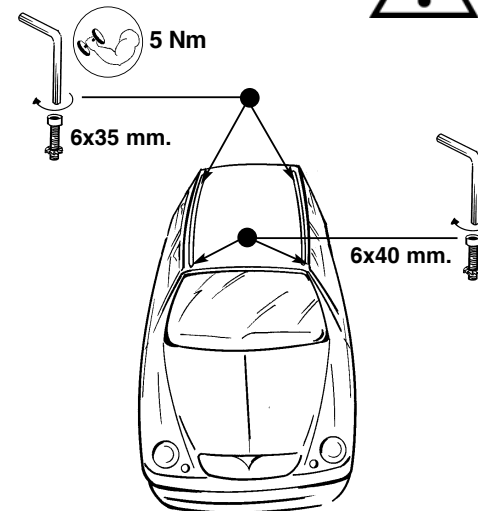

6x40 mm.



5 Nm

(IT) ANTERIORE  
 (GB) FRONT  
 (E) DELANTERO  
 (D) VORDERE  
 (F) AVANT  
 (NL) VOORSTE G.  
 (P) R FRENTE  
 (H) ELSŐ RÚD  
 (PL) PRZOD  
 (SLO) SPREDAJ  
 (HR) PREDNJI



6

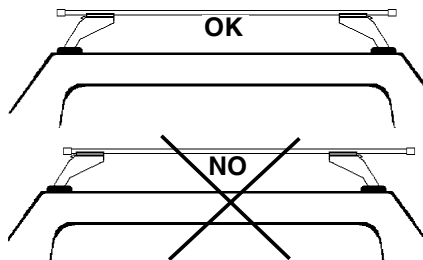

(IT) CENTRARE IL P. TUTTO SUL TETTO  
 (GB) CENTRE THE UNIVERSAL BAR CARRIER ON THE ROOF  
 (E) CENTRAR EL PORTAEQUIPAJES SOBRE EL TECHO  
 (D) LASTENTRÄGER AUF DEM DACH ZENTRIEREN  
 (F) CENTRER LE PORTE-TOUT SUR LE TOIT  
 (NL) PLAATS DE UNIVERSELE DRAGER IN HET MIDDEN VAN HET DAK  
 (P) CENTRAR AS BARRAS PORTA BAGAGENS NO TEJADILHO  
 (H) HELYEZZE KÖZÉPRE A RUDAKAT  
 (PL) WYSRODKOWAC BAGAZNIK NA DACHU  
 (SLO) CENTRIRATI PRILJAJNIK NA STREHO  
 (HR) CENTRIRATI NOSA-E NA KROV

7



10 Nm

(IT) AVVITARE (A FONDO)  
 (GB) TO SCREW (DOWN)  
 (E) APRETAR (A FONDO)  
 (D) FESTSCHRAUBEN  
 (F) VISSER (À FOND)  
 (NL) VASTSCHROEVEN  
 (P) APERTAR POR BAIXO  
 (H) MEGHÚZNI  
 (PL) WKRECIĆ DO KONCA  
 (SLO) PRIVITI (DO KONCA)  
 (HR) PRI-VRSTITI (DO KRAJA)

8

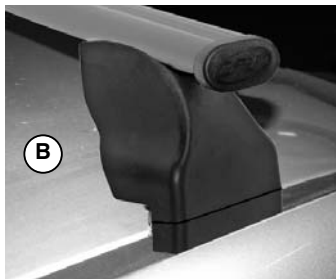
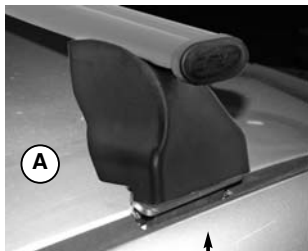

(IT) INSERIRE  
 (GB) INSERT  
 (E) CUBRIR  
 (D) STOPFEN  
 (F) ENFILER  
 (P) INSERIR  
 (NL) BEVESTIG  
 (H) TOLJA FEL  
 (PL) NALOZIC  
 (SLO) VSTAVITI  
 (HR) PREKRITI